

⚠ Safety instructions

The instructions for installation and use must be strictly observed in order to avoid the risk of electric shock or fire.

⚠ Consignas de seguridad
El no cumplimiento estricto de las instrucciones de instalación y uso puede implicar riesgos de choque eléctrico o incendio.

⚠ Instruções de segurança
Não respeitar estritamente as condições de instalação e de utilização poderá proocar riscos de choque eléctrico ou de incêndio.

⚠ Przepisy bezpieczeństwa
Niezastosowanie się ściśle do warunków instalacji i użytkowania może przyczynić porażeniem prądem lub pożarem.

⚠ Συστάσεις ασφαλείας
Η μη αυστηρή τήρηση των συνθηκών εγκατάστασης και χρήσης μπορεί να επιφέρει κινδύνους ηλεκτροπληξίας ή πυρκαγιάς.

⚠ Biztonsági előírások
A beszerelési és használati feltételek szigorú betartásának elmulasztása áramütés vagy tűz kockázatával jár.

⚠ Instrucțiuni de siguranță
Nerespectarea strictă a condițiilor de instalare și utilizare poate genera riscuri de șocuri electrice sau incendii.

⚠ Указания за безопасност
Неспазването стриктно на указанията за съгласяване и използване може да доведе до риск от токов удар или пожар.

⚠ Varnostna navodila
Neupoštevanje vseh pogojev instalacije in uporabe lahko povzroči nevarnost električnega udara ali požara.

⚠ Sigurnosne napomene
Ako se ne pridržavate strogo uvjeta za instalaciju i uporabu, može doći do strujnog udara ili požara.

⚠ Bezpečnostní pokyny
Nedodržení stanovených podmínek instalace a používání může vést k rizikům zasažení elektrickým proudem nebo požáru.

⚠ Bezpečnostné nariadenia
V prípade nedodržania presných podmienok týkajúcich sa inštalácie a používania hrozí riziko úrazu elektrickým prúdom alebo vzniku požiaru.

⚠ Sigurnosne preporuke
Ukoliko se ne pridržavate striktno uslova instaliranja i korišćenja, može doći dostrujnog udara ili požara.

— N

— L

--- ⊥

- | | | |
|---------------------------|---|---------------------------------------|
| • Neutral = blue | • Phase = all but blue and green/yellow | • Earth = green/yellow |
| • Neutro = azul | • Fase = todos excepto azul e verde/amarelo | • Terra = verde/amarelo |
| • Neutro = azul | • Fase = todos excepto azul y verde/amarillo | • Tierra = verde/amarillo |
| • Neutrálny = niebieski | • Fazovy = inny niż niebieski i zielono-żółty | • Uziemienie = zielono-żółty |
| • Ουδέτερος = Μπλε | • Φάση = όλα εκτός από μπλε και πράσινο/κίτρινο | • Γειωση = Πράσινο/Κίτρινο |
| • Nulla = kék | • Fázis = bármilyen szín, kivéve a kékét és a zöld-sárgát | • Védőföld = Zöld/Sárga |
| • Neutru = albastru | • Faza = oricare, cu exceptia albastru si galben/verde | • Impamantare = verde/galben |
| • Нейтрала = синьо | • Фаза = всичко освен синьо, зелено/жълто | • Земля = зелено/жълто |
| • Ničelni vodnik = modra | • Fazni vodnik = katerakoli, razen modre in zeleno/rumene | • Ozemljitveni vodnik = zelena/rumena |
| • Nultí provodník = plava | • Fazní provodník = sve osim plave i zelene/žute boje | • Uzemljenje = zelena/žuta |
| • Střední vodič = modra | • Fázový vodič = všechny mimo modré a žlutozelené | • Zemní vodič = zelená/žlutá |
| • Nulový vodič = modra | • Fáza = ktorákoľvek okrem modrá a zelená/žltá | • Uzemnienie = zelená/žltá |
| • Nula = plava | • Faza = sve osim plave i zelene/žute | • Zemlja = zelena/ žuta |

3 964 30/31

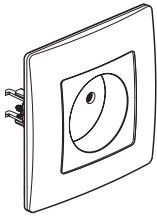

16 A - 230 V~

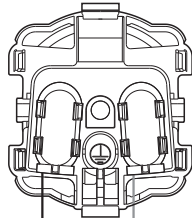

3 964 32/33/75/76

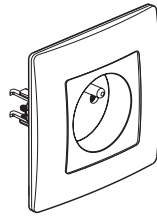

16 A - 230 V~

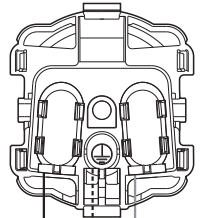
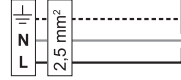

3 964 34/35/73/74

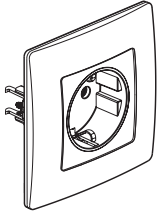

16 A - 230 V~

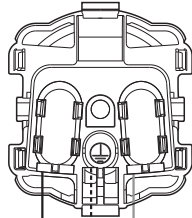
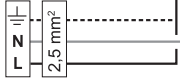

3 964 36/37

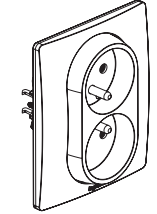

16 A - 230 V~

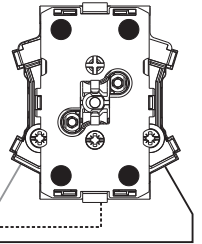

3 964 38/39

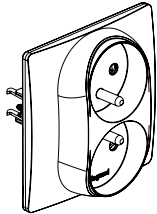

16 A - 230 V~

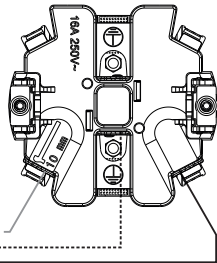

3 964 40/41/77/78

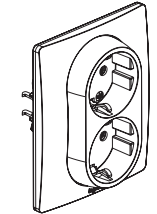

16 A - 230 V~

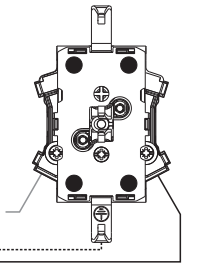

3 964 48/49

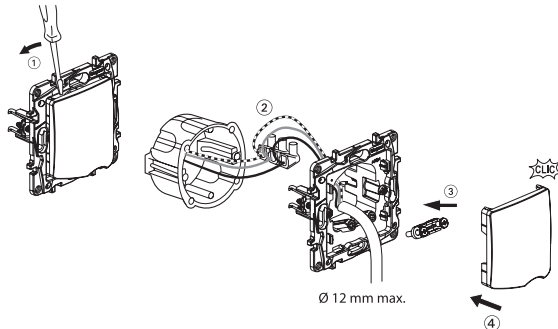
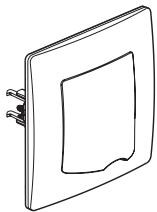

Ø 12 mm max.