

DESPIECE SPAREPARTS

**GENERADOR INVERTER:
BXGNI4000E**

MOTOR: XY170F-1A

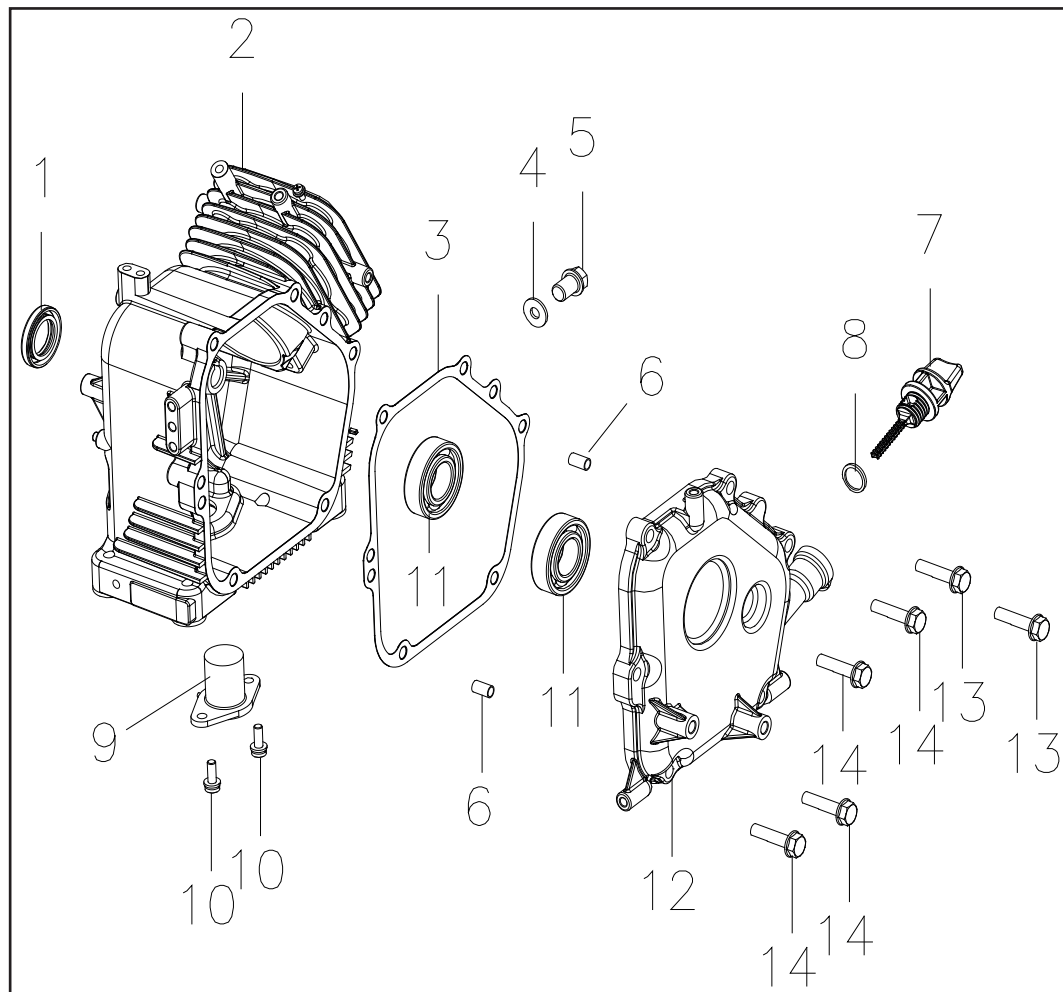



Nº	REF.	DESCRIPCIÓN (ES)	DESCRIPTION (EN)
1	SP-XY170F1A-A01	RETEN	OIL SEAL
2	SP-XY170F1A-A02	BLOQUE MOTOR	CRANKCASE
3	SP-XY170F1A-A03	JUNTA BLOQUE MOTOR	CRANKCASE GASKET
4	SP-XY170F1A-A04	JUNTA Ø12,3XØ18X2	GASKET Ø12.3XØ18X2
5	SP-XY170F1A-A05	TORNILLO M8X11,5	BOLT M8X11.5
6	SP-XY170F1A-A06	PASADOR	PIN
7	SP-XY170F1A-A07	VARILLA NIVEL ACEITE	ENGINE OIL GAUGE
8	SP-XY170F1A-A08	TORICA Ø10X3.55	O RING Ø10X3.55
9	SP-XY170F1A-A09	SENSOR NIVEL ACEITE	OIL LEVER SENSOR
10	SP-XY170F1A-A10	TORNILLO M6X16	INNER HEXAGON SCREW M6X16
11	SP-XY170F1A-A11	COJINETE 6205	BEARING 6205
12	SP-XY170F1A-A12	TAPA BLOQUE MOTOR	CRANKCASE CAP
13	SP-XY170F1A-A13	TORNILLO M8X35	HEXAGON FLANGE BOLTS M8X35
14	SP-XY170F1A-A14	TORNILLO M8X40	HEXAGON FLANGE BOLTS M8X40

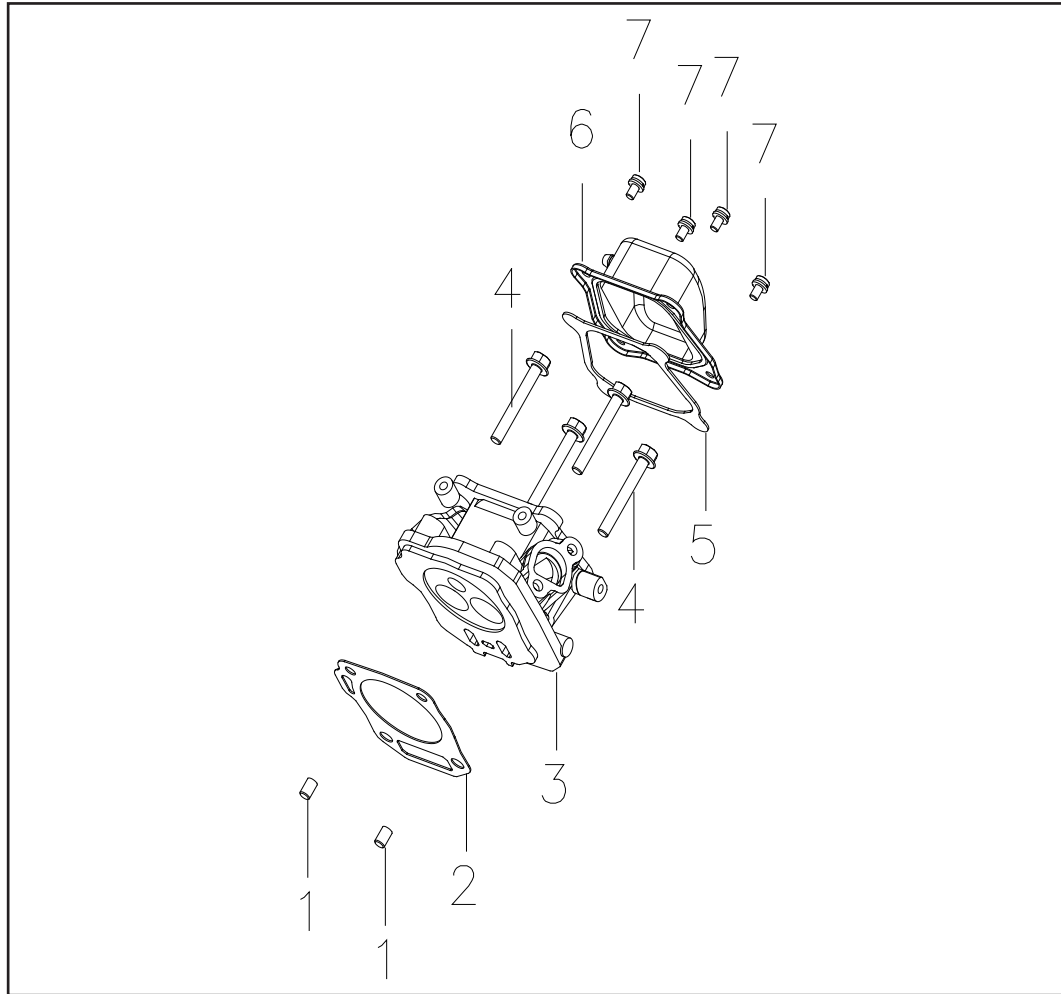

Nº	REF.	DESCRIPCIÓN (ES)	DESCRIPTION (EN)
1	SP-XY170F1A-B01	PASADOR Ø10X15,7	DOWEL PIN Ø10X15.7
2	SP-XY170F1A-B02	JUNTA CULATA	CYLINDER HEAD GASKET
3	SP-XY170F1A-B03	CULATA	CYLINDER HEAD COMPONENT
4	SP-XY170F1A-B04	TORNILLO M8X60	HEXAGON FLANGE BOLTS M8X60
5	SP-XY170F1A-B05	JUNTA TAPA VALVULAS	GASKET OF RESPIRATOR
6	SP-XY170F1A-B06	TAPA VALVULAS	RESPIRATOR
7	SP-XY170F1A-B07	TORNILLO M6X16	HEXAGON FLANGE BOLTS M6X16

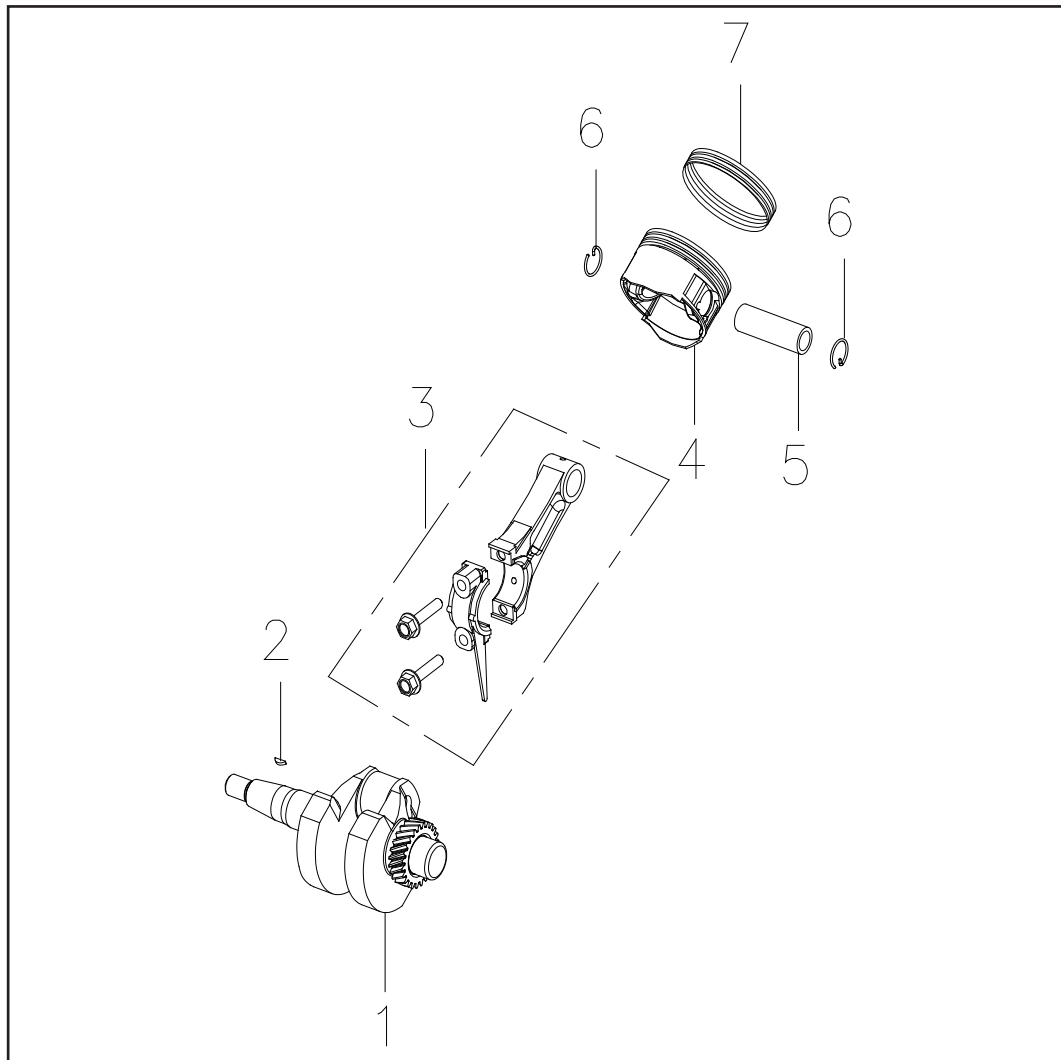

Nº	REF.	DESCRIPCIÓN (ES)	DESCRIPTION (EN)
1	SP-XY170F1A-C01	CIGÜEÑAL	CRANSHAFT CONNECTING ROD ASSY
2	SP-XY170F1A-C02	CHAVETA	WOODRUFF KEY
3	SP-XY170F1A-C03	BIELA	CONNECTING ROD
4	SP-XY170F1A-C04	PISTON	PISTON
5	SP-XY170F1A-C05	BURLON PISTON	PISTON PIN
6	SP-XY170F1A-C06	CLIP SUJECION PISTON	PISTON PIN CLIP
7	SP-XY170F1A-C07	JUEGO SEGMENTOS	PISTON RING

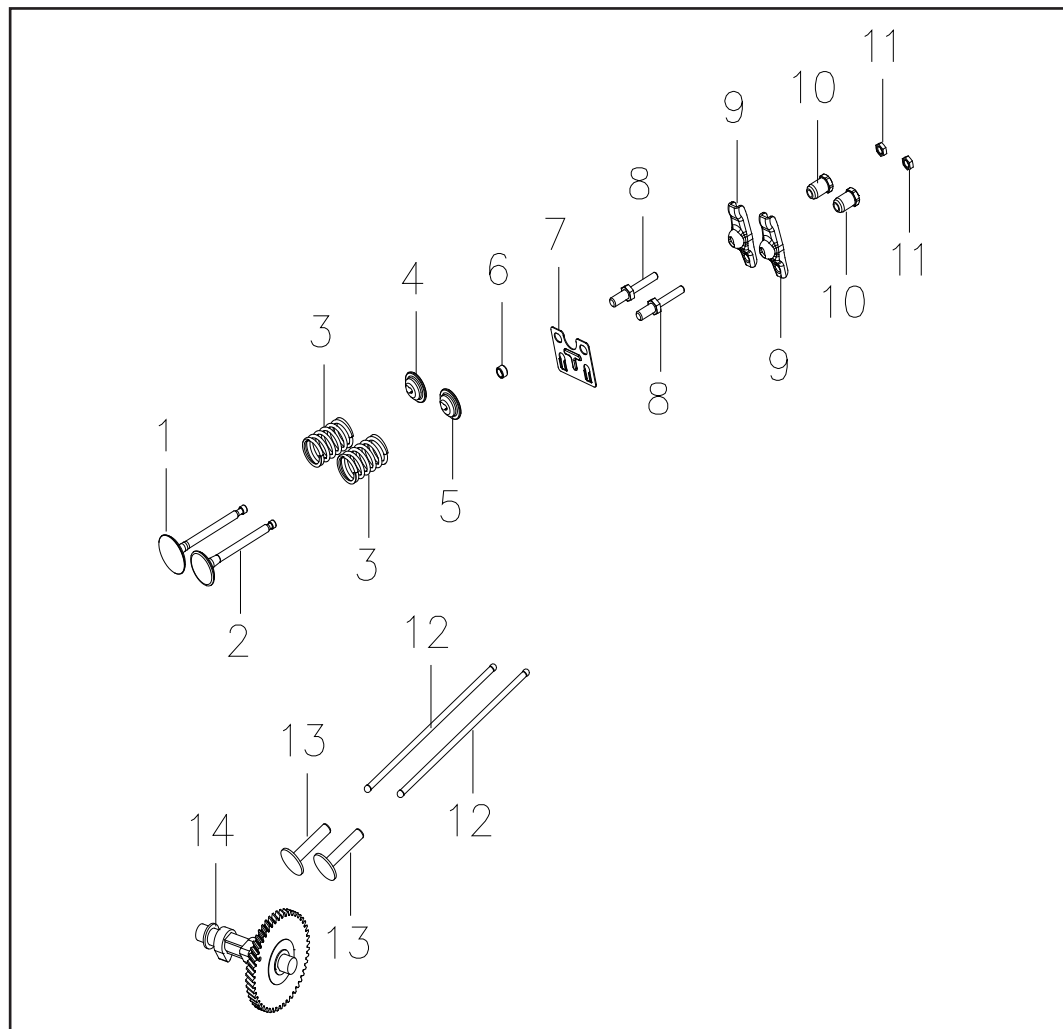

Nº	REF.	DESCRIPCIÓN (ES)	DESCRIPTION (EN)
1	SP-XY170F1A-D01	VALVULA ADMISION	INTAKE VALVE
2	SP-XY170F1A-D02	VALVULA ESCAPE	EXHAUST VALVE
3	SP-XY170F1A-D03	MUELLE VALVULA	VALVE SPRING
4	SP-XY170F1A-D04	ASIENTO MUELLE VALVULA ADMISION	INTAKE VALVE SPRING PLATE
5	SP-XY170F1A-D05	ASIENTO MUELLE VALVULA ESCAPE	EXHAUST VALVE SPRING PLATE
6	SP-XY170F1A-D06	TOPE VALVULA	COVER OF EXHAUST
7	SP-XY170F1A-D07	PLACA GUIA	GUIDE PLATE
8	SP-XY170F1A-D08	TORNILLO BALANCINES	ROCKER ARM BOLT
9	SP-XY170F1A-D09	BALANCINES	VALVE ROCKER ARM
10	SP-XY170F1A-D10	TUERCA BALANCINES	VALVE ROCKER ARM NUT
11	SP-XY170F1A-D11	TUERCA BLOQUEO BALANCINES	VALVE ROCKER ARM LOCKER NUT
12	SP-XY170F1A-D12	VARILLA EMPUJE	PUSHING ROD
13	SP-XY170F1A-D13	ASIENTO VARILLA	TAPPET
14	SP-XY170F1A-D14	ARBOL LEVAS	CAMSHAFT

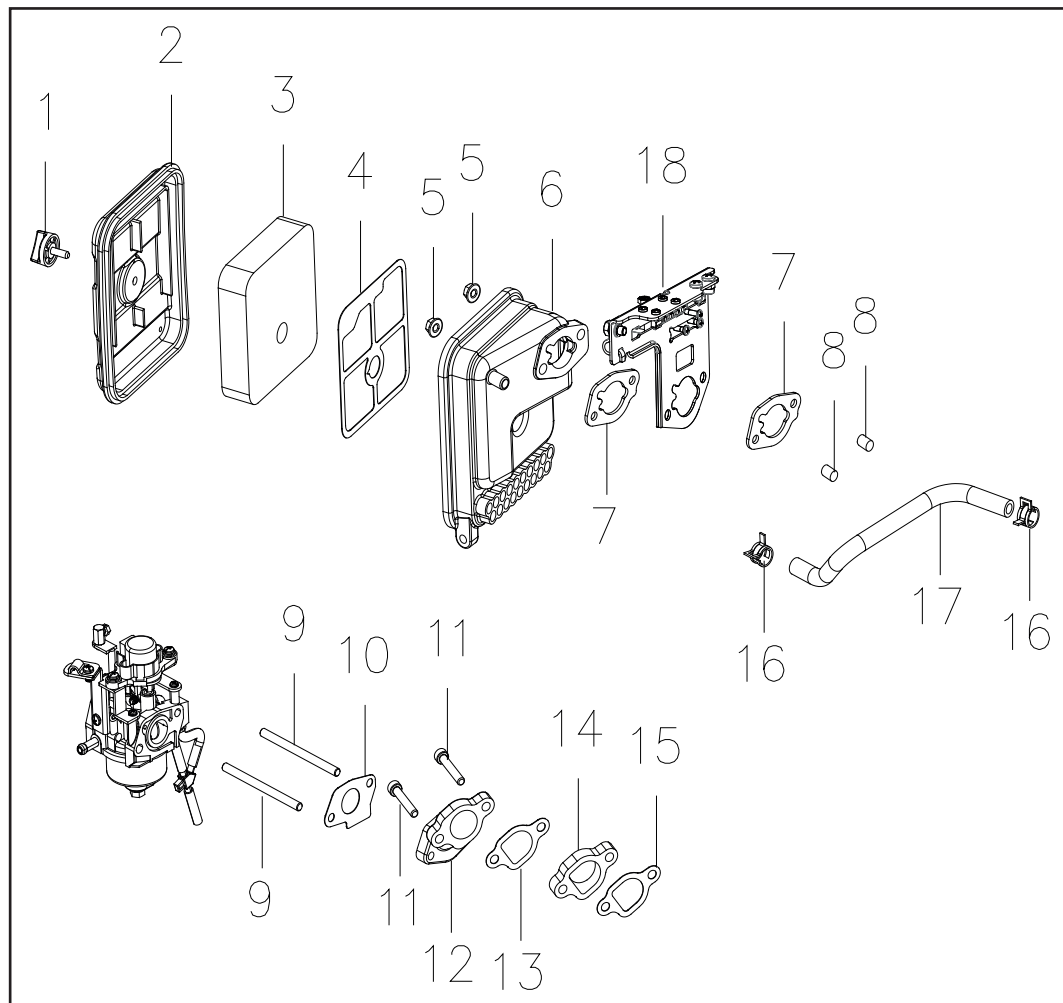

Nº	REF.	DESCRIPCIÓN (ES)	DESCRIPTION (EN)
1	SP-XY170F1A-E01	PALOMILLA	EASY DISASSEMBLY BOLT
2	SP-XY170F1A-E02	TAPA FILTRO AIRE	AIR CLEANER CAP
3	SP-XY170F1A-E03	ELEMENTO FILTRANTE	FOAM
4	SP-XY170F1A-E04	SOPORTE ELEMENTO	FOAM BRACKET
5	SP-XY170F1A-E05	TUERCA M6	HEXAGON FLANGE NUTS M6
6	SP-XY170F1A-E06	BASE FILTRO AIRE	AIR CLEANER ASSY
7	SP-XY170F1A-E07	JUNTA FILTRO AIRE	AIR CLEANER GASKET
8	SP-XY170F1A-E08	CASQUILLO	AIR FILTER BUSHING
9	SP-XY170F1A-E09	ESPARRAGO M6	STUD BOLT M6
10	SP-XY170F1A-E10	JUNTA CARBURADOR	CARBURETOR GASKET
11	SP-XY170F1A-E11	TORNILLO	HEXAGON HEAD SET SCREWS
12	SP-XY170F1A-E12	PLACA AISLANTE	INSULATION BOARD
13	SP-XY170F1A-E13	JUNTA ADMISION AIRE	AIR INTAKE GASKET
14	SP-XY170F1A-E14	CONECTOR CARBURADOR	INSULATION BOARD COMPONENTS
15	SP-XY170F1A-E15	JUNTA CONECTOR	INSULATION BOARD GASKET
16	SP-XY170F1A-E16	ABRAZADERA	PIPE HOOP
17	SP-XY170F1A-E17	TUBO	OUTLET PIPE
18	SP-XY170F1A-E18	ESTARTER AUTOMATICO	AUTO-CHOKE

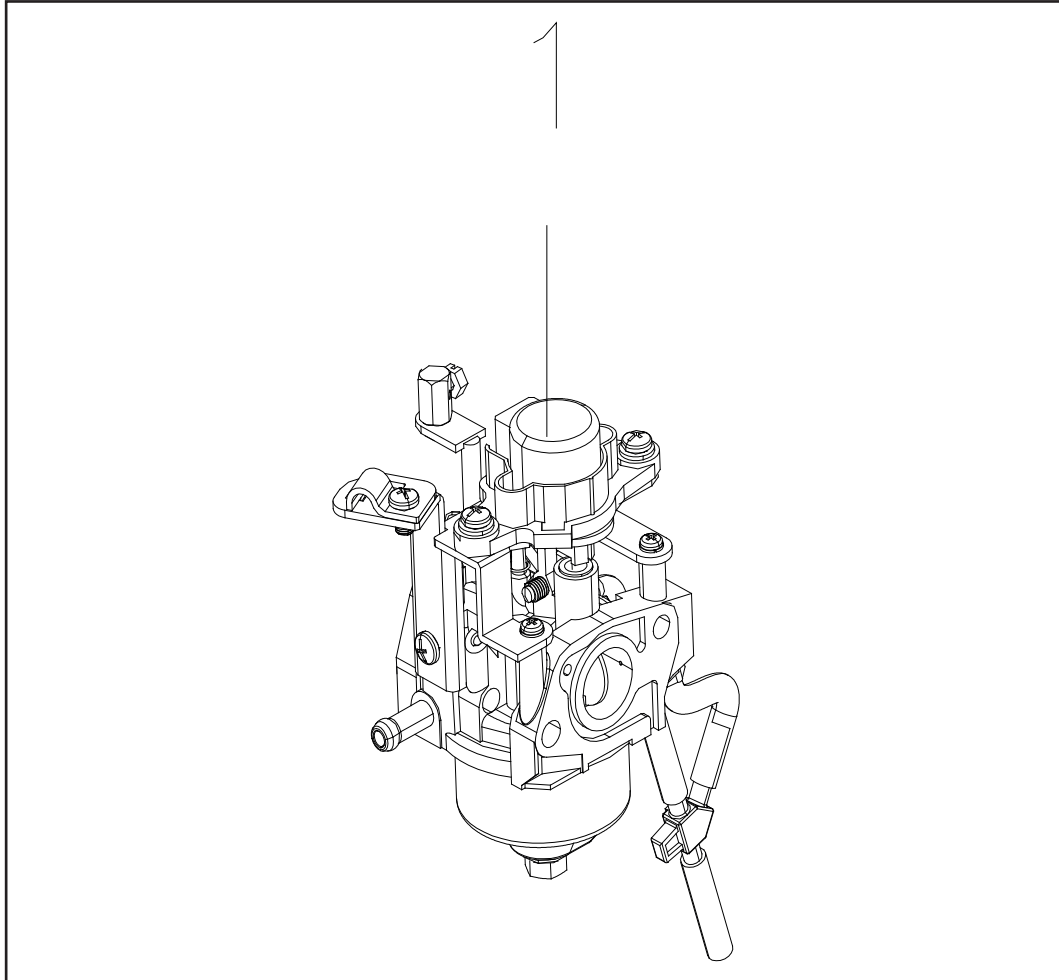

Nº	REF.	DESCRIPCIÓN (ES)	DESCRIPTION (EN)
1	SP-XY170F1A-F01	CARBURADOR	CARBURETOR

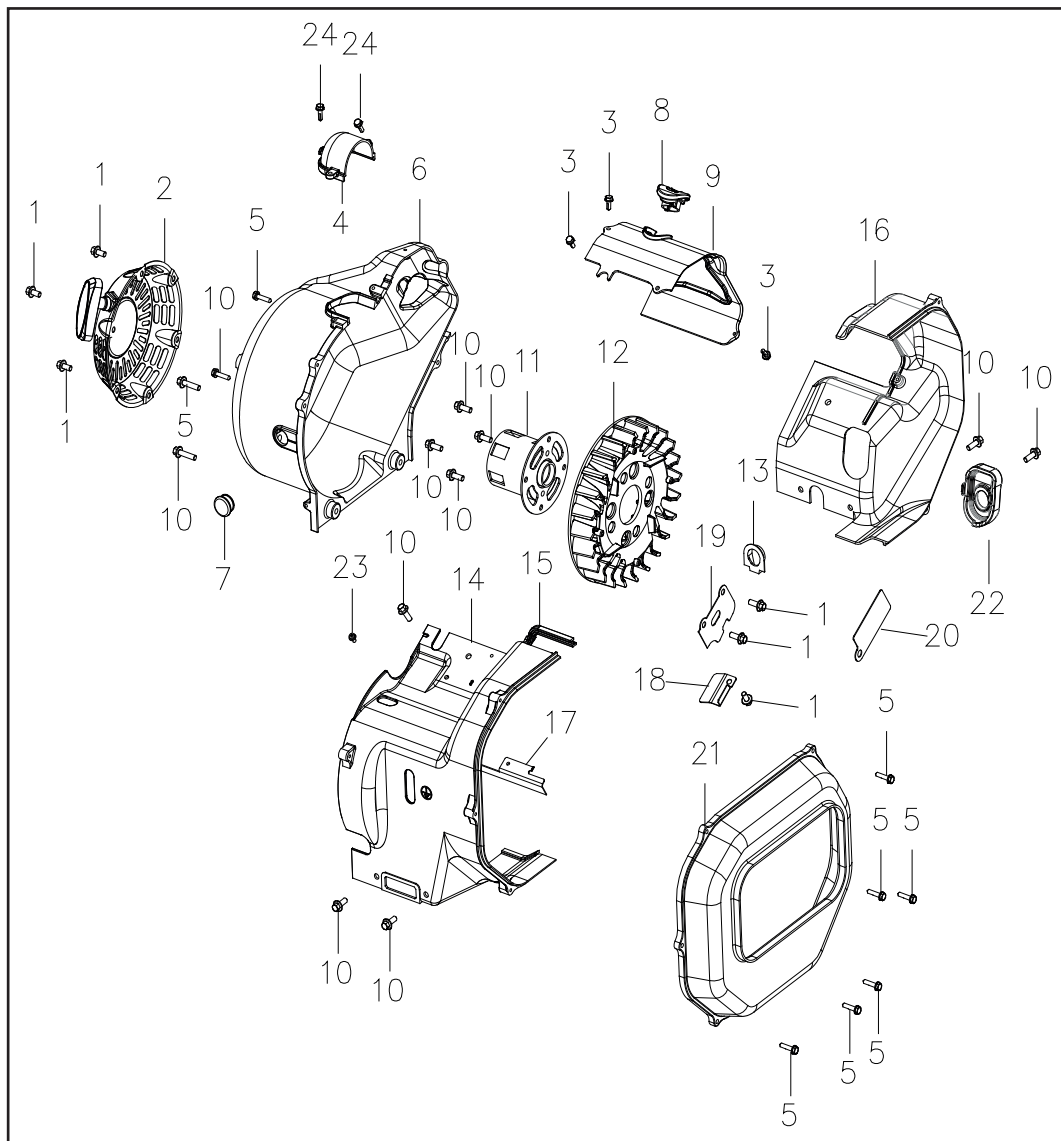

Nº	REF.	DESCRIPCIÓN (ES)	DESCRIPTION (EN)
1	SP-XY170F1A-G01	TORNILLO M6X12	HEXAGON FLANGE BOLTS M6X12
2	SP-XY170F1A-G02	ARRANCADOR MANUAL	RECOIL STARTER
3	SP-XY170F1A-G03	TORNILLO ST4,8X13	TAPPING SCREW ST4.8X13
4	SP-XY170F1A-G04	CUBIERTA MOTOR ARRANQUE	STARTING MOTOR COVER
5	SP-XY170F1A-G05	TORNILLO ST4,8X22	TAPPING SCRW ST4.8X22
6	SP-XY170F1A-G06	ALOJAMIENTO VENTILADOR	FAN VOLUTE
7	SP-XY170F1A-G07	TAPON	PEEPHOLE PLUG
8	SP-XY170F1A-G08	TAPON DE SELLADO	HIGH PRESSURE CAP SEALING RING
9	SP-XY170F1A-G09	TAPA SUPERIOR	COVER OF RESPIRATOR
10	SP-XY170F1A-G10	TORNILLO M6X16	HEXAGON FLANGE BOLTS M6X16
11	SP-XY170F1A-G11	ACOPLE ARRANCADOR	STARTING HUB
12	SP-XY170F1A-G12	VENTILADOR	COOLING FAN
13	SP-XY170F1A-G13	JUNTA DRENAJE ACEITE	OIL DRAIN
14	SP-XY170F1A-G14	TAPA LATERAL IZQUIERDA	AIR GUIDE B
15	SP-XY170F1A-G15	JUNTA TAPA LATERAL	WINDSHIELD RUBBER STRIP
16	SP-XY170F1A-G16	TAPA LATERAL DERECHA	AIR GUIDE A
17	SP-XY170F1A-G17	DEFLECTOR AIRE I	AIR DEFLECTOR I
18	SP-XY170F1A-G18	DEFLECTOR AIRE II	AIR DEFLECTOR II
19	SP-XY170F1A-G19	DEFLECTOR AIRE III	AIR DEFLECTOR III
20	SP-XY170F1A-G20	DEFLECTOR AIRE IV	AIR DEFLECTOR IV
21	SP-XY170F1A-G21	CUBIERTA ESCAPE	MUFFLER COVER
22	SP-XY170F1A-G22	JUNTA ADMISION ACEITE	OIL INLET GASKET
23	SP-XY170F1A-G23	TORNILLO M5X10	HEXAGON FLANGE BOLTS M5X10
24	SP-XY170F1A-G24	TORNILLO ST4,8X16	TAPPING SCREWS ST4.8X16

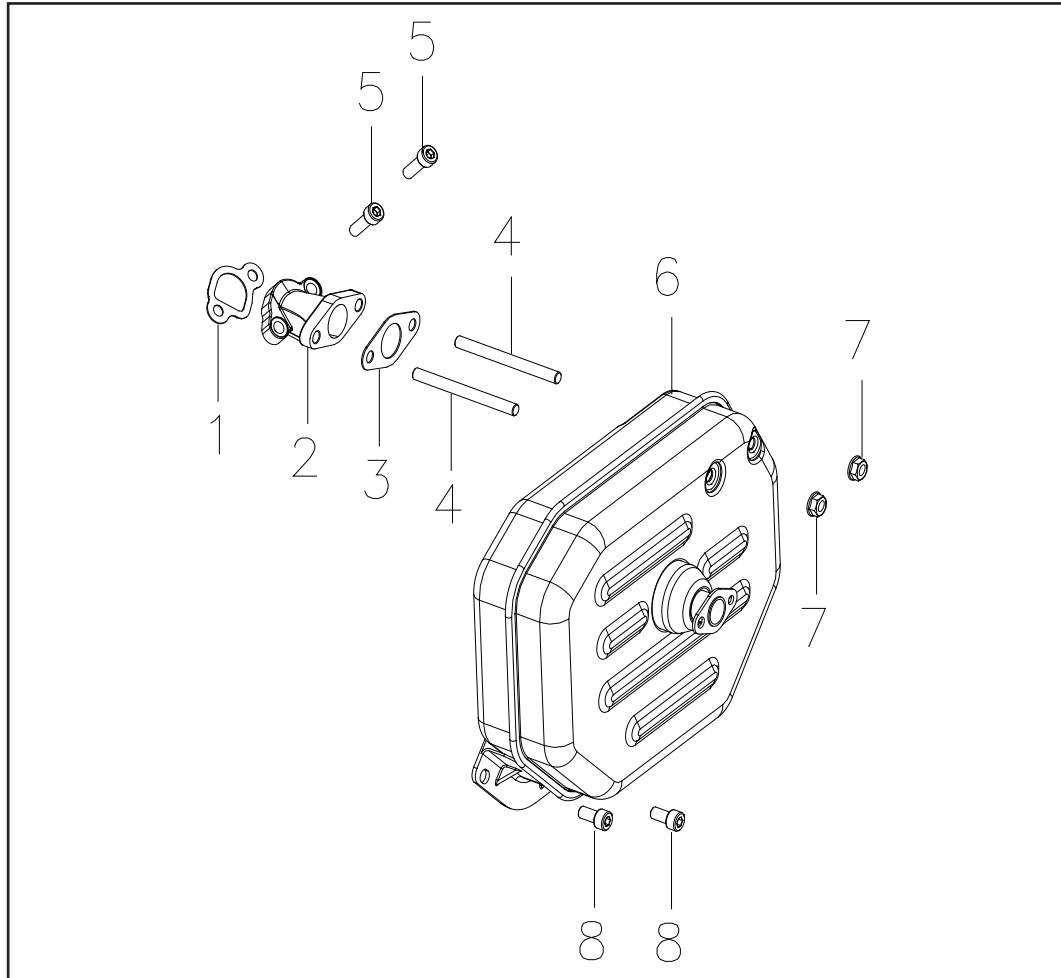

Nº	REF.	DESCRIPCIÓN (ES)	DESCRIPTION (EN)
1	SP-XY170F1A-H01	JUNTA TUBO ESCAPE	EXHAUST PIPE GASKET
2	SP-XY170F1A-H02	TUBO ESCAPE	MUFFLER PIPE
3	SP-XY170F1A-H03	JUNTA ESCAPE	MUFFLER GASKET
4	SP-XY170F1A-H04	ESPERRAGO M8	STUD BOLT M8
5	SP-XY170F1A-H05	TORNILLO M8X25	BOLTS M8X25
6	SP-XY170F1A-H06	ESCAPE	MUFFLER
7	SP-XY170F1A-H07	TUERCA M8	HEXAGON FLANGE NUTS M8
8	SP-XY170F1A-H08	TORNILLO M8X16	BOLTS M8X16

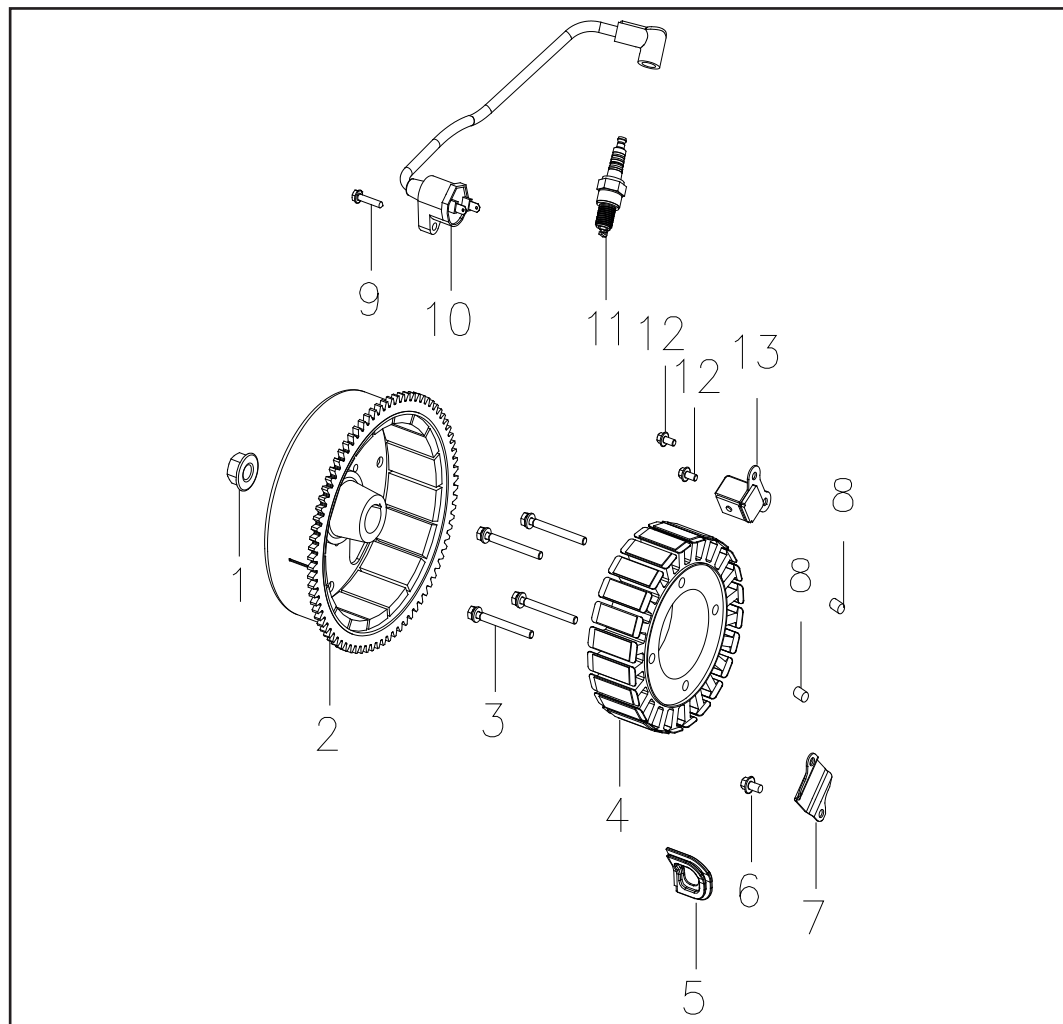

Nº	REF.	DESCRIPCIÓN (ES)	DESCRIPTION (EN)
1	SP-XY170F1A-I01	TUERCA M14	HEXAGON FLANGE NUTS M14
2	SP-XY170F1A-I02	VOLANTE INERCIA	FLYWHEEL
3	SP-XY170F1A-I03	TORNILLO M5X60	HEXAGON SCREW M5X60
4	SP-XY170F1A-I04	ESTATOR	STATOR
5	SP-XY170F1A-I05	PASA CABLES	BUSHING
6	SP-XY170F1A-I06	TORNILLO M6X12	HEXAGON FLANGE BOLTS M6X12
7	SP-XY170F1A-I07	SOPORTE	CLAMP
8	SP-XY170F1A-I08	CASQUILLO Ø8X14	POSITIONING SLEEVES Ø8X14
9	SP-XY170F1A-I09	TORNILLO ST4,8X22	TAPPING SCREW ST4.8X22
10	SP-XY170F1A-I10	BOBINA BUJIA	IGNITION COIL
11	SP-BUJIA-F7RTC	BUJIA TORCH F7RTC	SPARK PLUG TORCH F7RTC
12	SP-XY170F1A-I12	TORNILLO M5X10	HEXAGON FLANGE BOLTS M5X10
13	SP-XY170F1A-I13	SENSOR REVOLUCIONES	RPM SENSOR

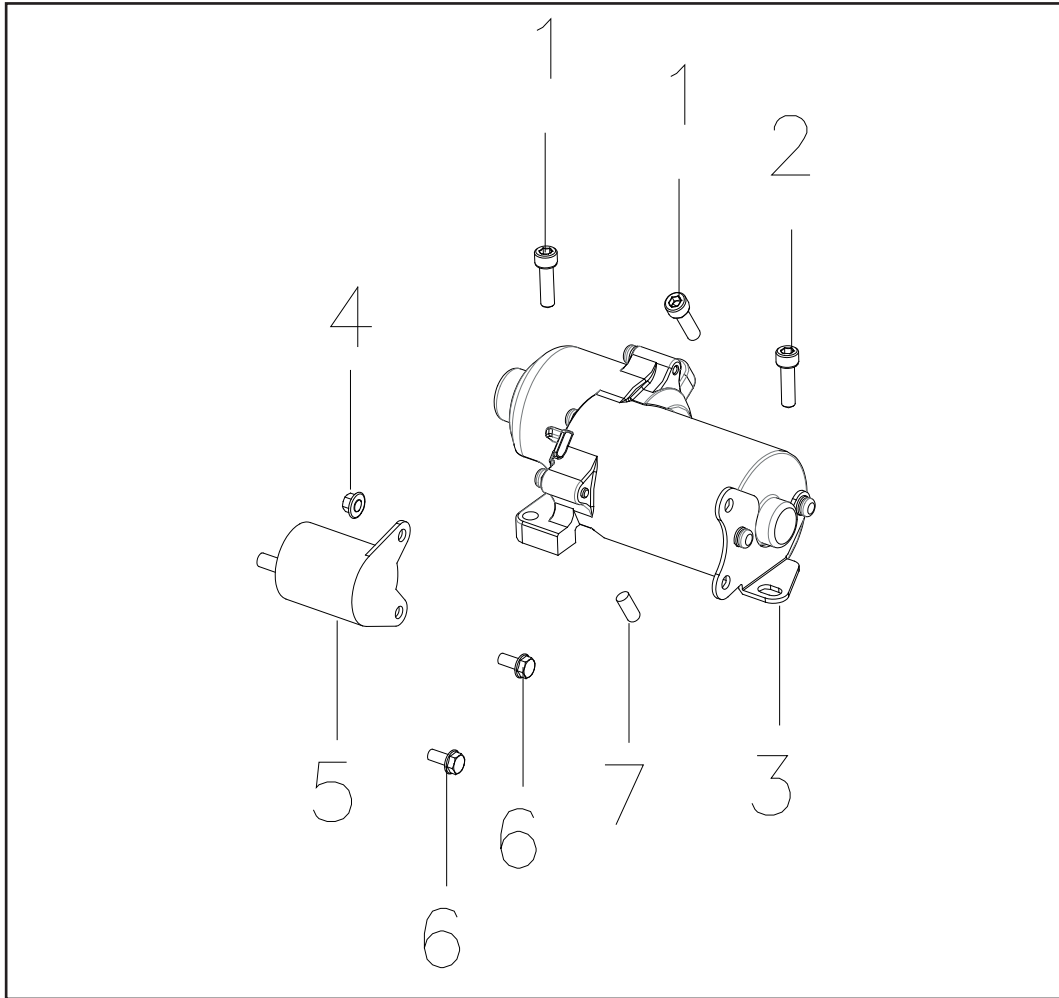

Nº	REF.	DESCRIPCIÓN (ES)	DESCRIPTION (EN)
1	SP-XY170F1A-J01	TORNILLO M6X20	INNER HEXAGON SCREW M6X20
2	SP-XY170F1A-J02	TORNILLO M5X12	INNER HEXAGON SCREW M5X12
3	SP-XY170F1A-J03	MOTOR ARRANQUE	START MOTOR
4	SP-XY170F1A-J04	TUERCA M5	FLANGE NUT M5
5	SP-XY170F1A-J05	RELE	START RELAY
6	SP-XY170F1A-J06	TORNILLO M5X10	HEXAGON FLANGE BOLTS M5X10
7	SP-XY170F1A-J07	PASADOR Ø6X8	DOWEL PIN Ø6X8

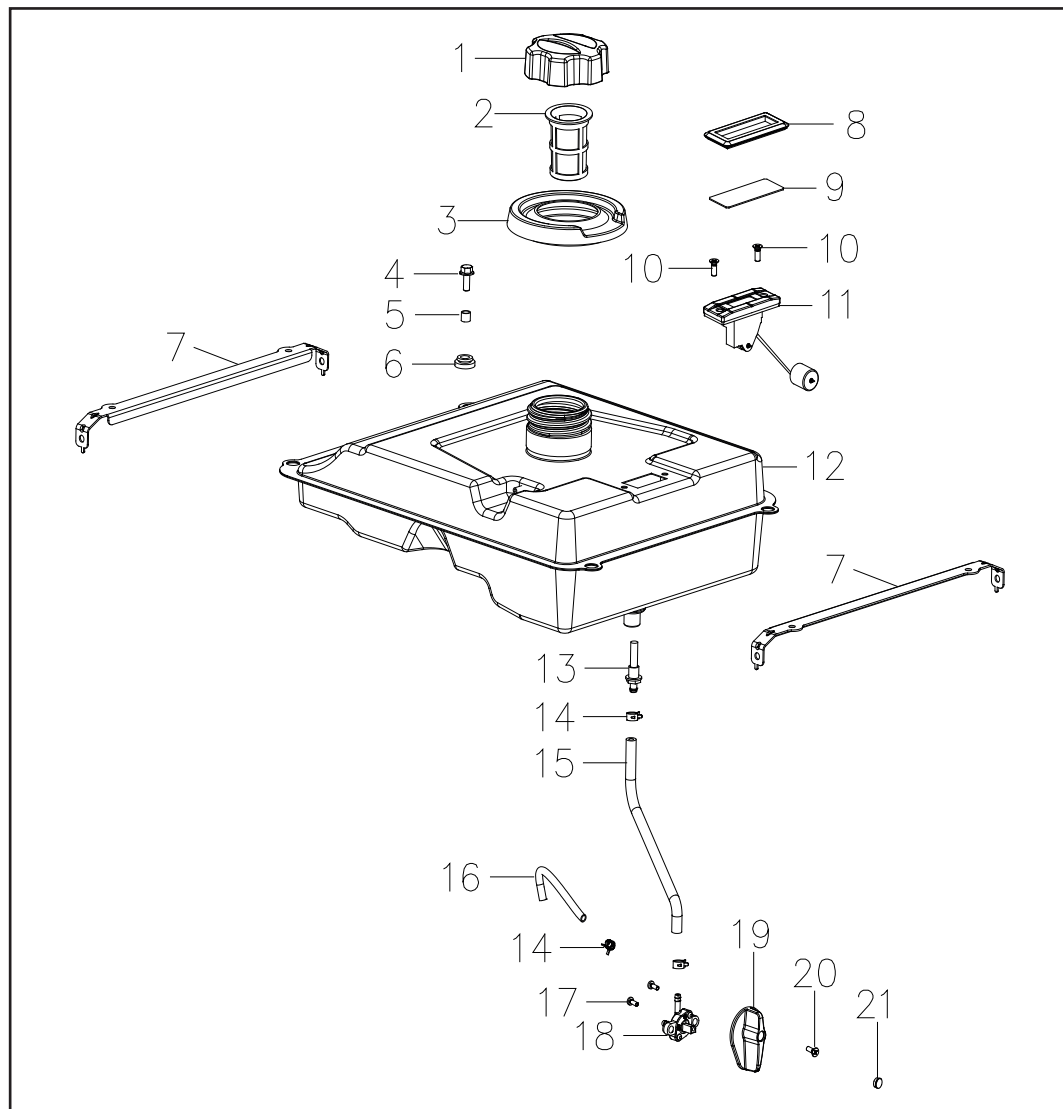

Nº	REF.	DESCRIPCIÓN (ES)	DESCRIPTION (EN)
1	SP-39i-K01	TAPON DEPOSITO COMBUSTIBLE	FUEL TANK CAP ASSY
2	SP-39i-K02	PRE FILTRO COMBUSTIBLE	FUEL FILTER
3	SP-39i-K03	GOMA BOCA DEPOSITO	FUEL TANK PORT RUBBER PART
4	SP-39i-K04	TORNILLO M6X16	PAN HEAD SCREW M6X16
5	SP-39i-K05	CASQUILLO	SHOCK PAD
6	SP-39i-K06	JUNTA DE GOMA	RUBBER SHOCK PAD
7	SP-39i-K07	SOPORTE DEPOSITO	TANK DEAD PLATE
8	SP-39i-K08	JUNTA INDICADOR	RUBBER OF OIL LEVEL GAUGE
9	SP-39i-K09	CRISTAL INDICADOR	WINDOW OF OIL LEVEL GAUGE
10	SP-39i-K10	TORNILLO M5X14	CROSS HEAD SCREW M5X14
11	SP-39i-K11	INDICADOR NIVEL COMBUSTIBLE	OIL LEVEL GAUGE
12	SP-39i-K12	DEPOSITO COMBUSTIBLE	FUEL TANK
13	SP-39i-K13	BOQUILLA DEPOSITO	TANK OUTLET
14	SP-39i-K14	ABRAZADERA Ø10	CLAMP Ø10
15	SP-39i-K15	TUBO COMBUSTIBLE Ø5XØ10X150	OIL TUBE Ø5XØ10X150
16	SP-39i-K16	TUBO COMBUSTIBLE Ø5XØ10X240	OIL TUBE Ø5XØ10X240
17	SP-39i-K17	TORNILLO ST4.8X13	SCREW ST4.8X13
18	SP-39i-K18	GRIFO COMBUSTIBLE	FUEL COCK
19	SP-39i-K19	MANGO GRIFO COMBUSTIBLE	FUEL COCK HANDLE
20	SP-39i-K20	TORNILLO M4X12	SCREW M4X12
21	SP-39i-K21	TAPON MANGO GRIFO	CAP OF FUEL COCK HANDLE

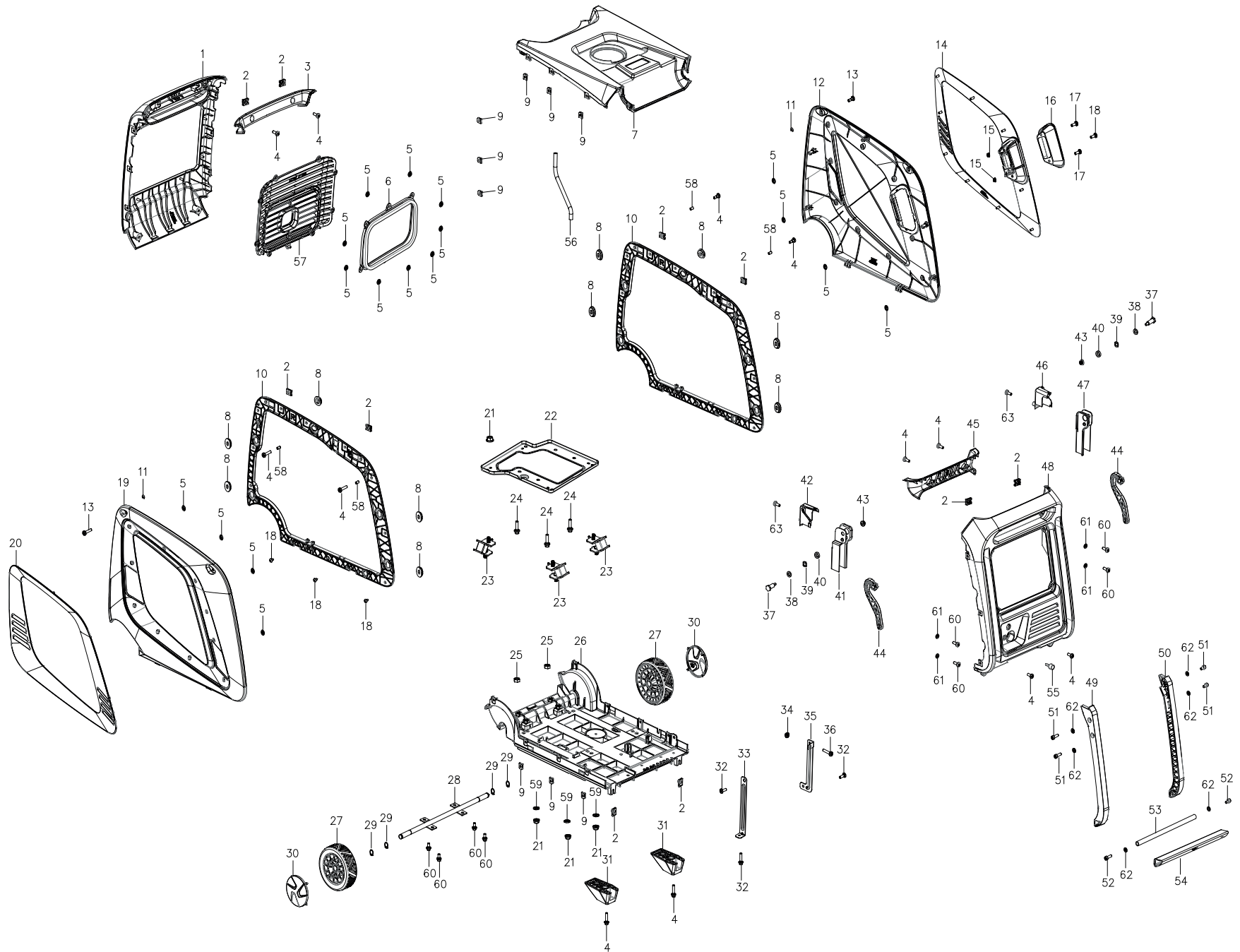

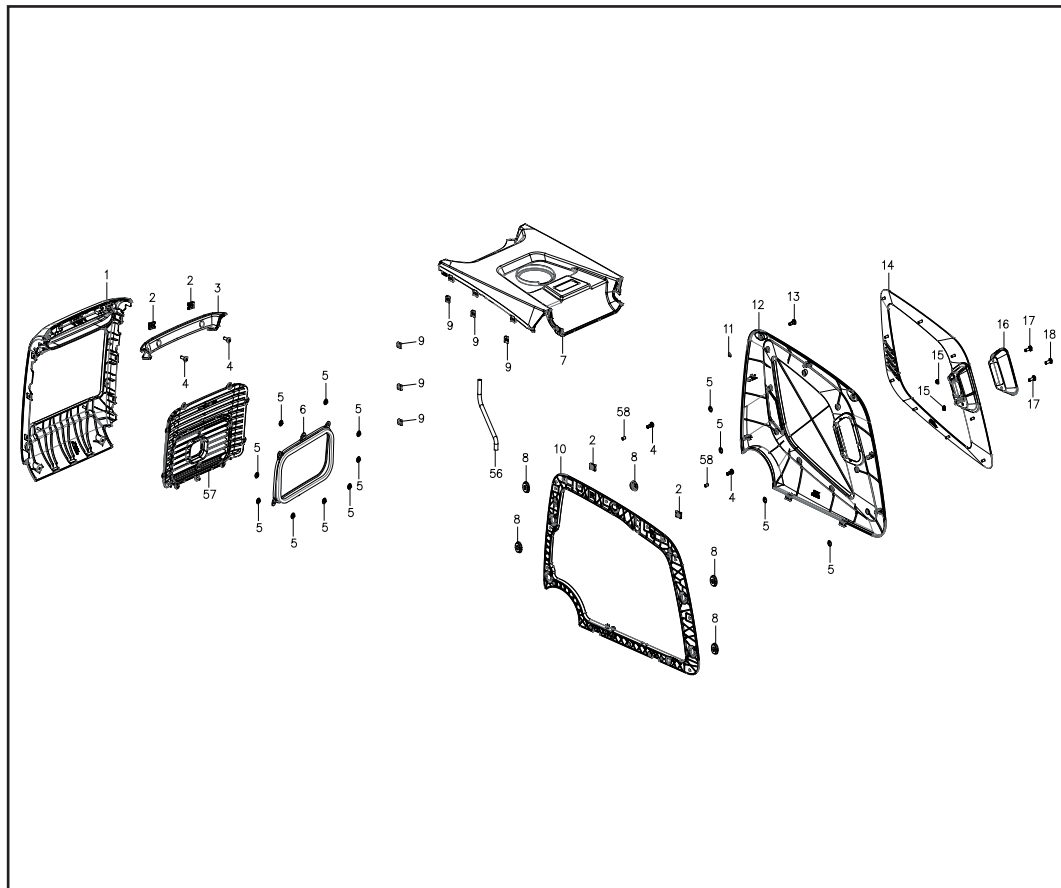

Nº	REF.	DESCRIPCIÓN (ES)	DESCRIPTION (EN)
1	SP-39i-L01	CARCASA TRASERA	BACK COVER OF SHELL
2	SP-39i-L02	TUERCA M6	CLIP NUT M6
3	SP-39i-L03	MANGO CARCASA TRASERA	HANDLE OF BACK COVER
4	SP-39i-L04	TORNILLO M6X16	PAN HEAD SCREW M6X16
5	SP-39i-L05	ARANDELA	WASHER
6	SP-39i-L06	JUNTA CUBIERTA ESCAPE	MUFFLER COVER SEAL
7	SP-39i-L07	CARCASA SUPERIOR	TOP COVER OF SHELL
8	SP-39i-L08	CASQUILLO DE GOMA	RUBBER BUCKLE
9	SP-39i-L09	TUERCA ST4,8	REED NUT ST4.8
10	SP-39i-L10	SOPORTE CUBIERTA LATERAL	SHELL SUPPORT FRAME
11	SP-39i-L11	ARANDELA GLOVER	SPLIT WASHER
12	SP-39i-L12HY	CUBIERTA LATERAL IZQUIERDA HY	LEFT COVER OF SHELL HY
13	SP-39i-L13	TORNILLO M6X16	SCREW M6X16
14	SP-39i-L14HY	CARCASA LATERAL IZQUIERDA HY	LEFT SIDE COVER HY
15	SP-39i-L15KP	TUERCA M4 KP	HEXAGON FLANGE NUTS M4 KP
16	SP-39i-L16HY	PROTECTOR HY	EDGE PROTECTOR HY
17	SP-39i-L17	TORNILLO M4X12	SCREW M4X12
18	SP-39i-L18	TORNILLO ST4,8X13	TAPPING SCREW ST4.8X13
56	SP-39i-L56	TUBO DRENAJE	DRAIN PIPE
57	SP-39i-L57	CUBIERTA ESCAPE	MUFFLER COVER
58	SP-39i-L58	CASQUILLO Ø6,5XØ9X4	BUSH 6.5X9X4

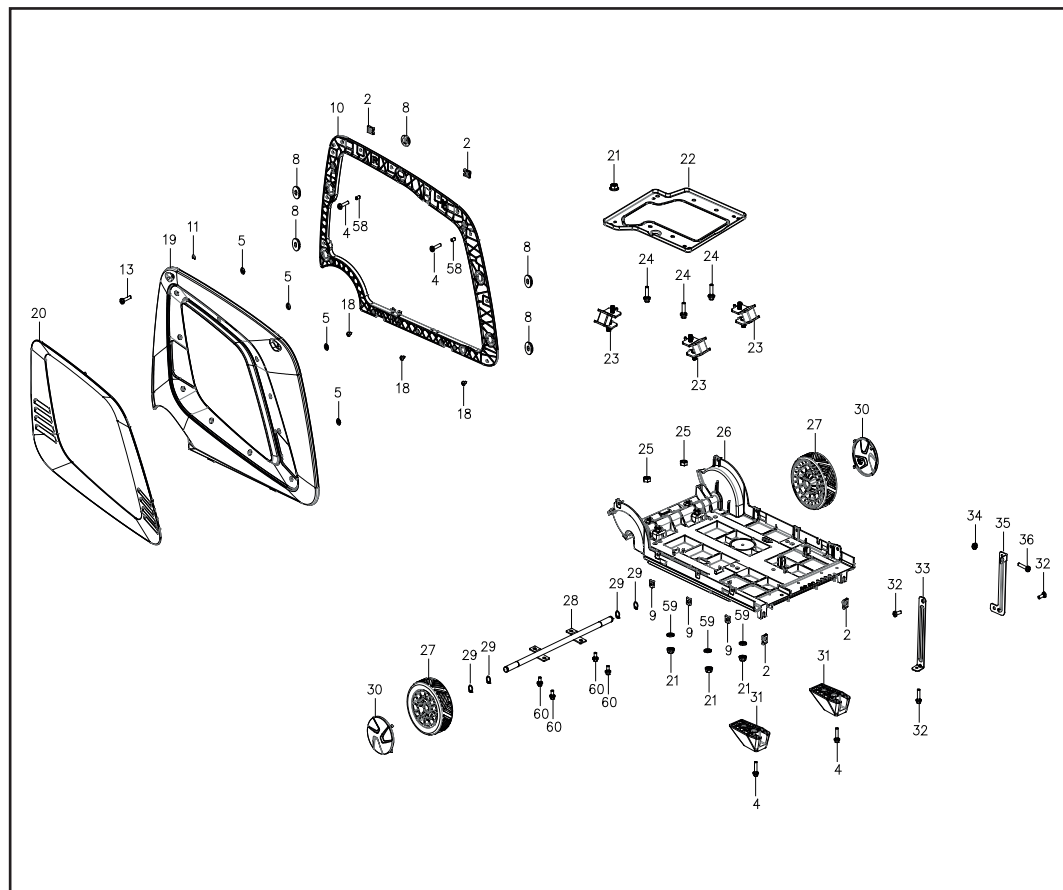

Nº	REF.	DESCRIPCIÓN (ES)	DESCRIPTION (EN)
2	SP-39i-L02	TUERCA M6	CLIP NUT M6
4	SP-39i-L04	TORNILLO M6X16	PAN HEAD SCREW M6X16
5	SP-39i-L05	ARANDELA	WASHER
8	SP-39i-L08	CASQUILLO DE GOMA	RUBBER BUCKLE
9	SP-39i-L09	TUERCA ST4,8	REED NUT ST4.8
10	SP-39i-L10	SOPORTE CUBIERTA LATERAL	SHELL SUPPORT FRAME
11	SP-39i-L11	ARANDELA GLOVER	SPLIT WASHER
13	SP-39i-L13	TORNILLO M6X16	SCREW M6X16
18	SP-39i-L18	TORNILLO ST4,8X13	TAPPING SCREW ST4.8X13
19	SP-39i-L19HY	CUBIERTA LATERAL DERECHA HY	RIGHT COVER OF SHELL HY
20	SP-39i-L20HY	CARCARA LATERAL DERECHA HY	RIGHT SIDE COVER HY
21	SP-39i-L21	TUERCA M8	HEXAGON FLANGE NUT M8
22	SP-39i-L22	TAPA MOTOR	COVER PLATE OF ENGINE
23	SP-39i-L23	SILENT BLOCK 1525-2	SHCOK PAD 1525-2
24	SP-39i-L24	TORNILLO M8X25	HEXAGON FLANGE BOLTS M8X25
25	SP-39i-L25	TUERCA M6	HEXAGON NUT M6
26	SP-39i-L26	BASE INVERTER	CHASSIS
27	SP-39i-L27	RUEDA TRASERA	REAR WHEEL ASSEMBLY
28	SP-39i-L28	EJE	AXLE ASSEMBLY
29	SP-39i-L29	CIRCLIP	CIRCLIP
30	SP-39i-L30HY	TAPA RUEDA TRASERA HY	REAR WHEEL CAP HY
31	SP-39i-L31	PIES DE GOMA	BOTTOM DAMPING FOOT
32	SP-39i-L32	TORNILLO M6X12	HEXAGON FLANGE BOLTS M6X12
33	SP-39i-L33	SOPORTE DERECHO INVERTER	INVERTER RIGHT HOLDER
34	SP-39i-L34	TUERCA M6	HEXAGON FLANGE NUT M6
35	SP-39i-L35	SOPORTE IZQUIERDO INVERTER	INVERTER LEFT HOLDER
36	SP-39i-L36	TORNILLO M6X25	HEXAGON FLANGE BOLTS M6X25
58	SP-39i-L58	CASQUILLO Ø6,5XØ9X4	BUSH 6.5X9X4
59	SP-39i-L59	JUNTA GBT96_2-8	GASKET GBT96_2-8
60	SP-39i-L60	TORNILLO M6X12	HEXAGON FLANGE BOLTS M6X12

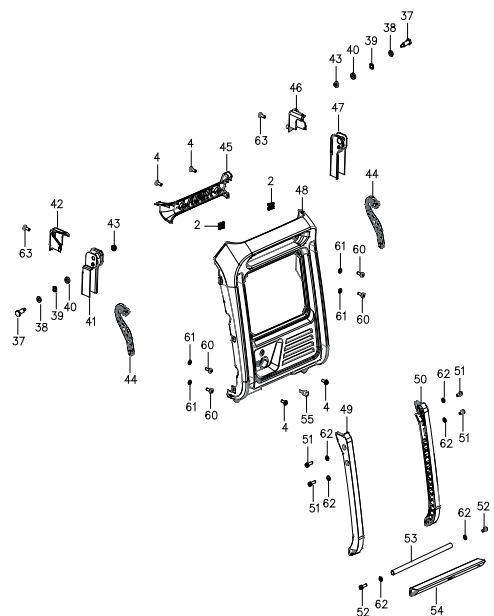

Nº	REF.	DESCRIPCIÓN (ES)	DESCRIPTION (EN)
2	SP-39i-L02	TUERCA M6	CLIP NUT M6
4	SP-39i-L04	TORNILLO M6X16	PAN HEAD SCREW M6X16
37	SP-39i-L37	TORNILLO	STEP BOLT
38	SP-39i-L38	JUNTA DE NYLON Ø10XØ16X2	NYLON GASKET Ø10XØ16X2
39	SP-39i-L39	ARANDELA	WAVE WASHER
40	SP-39i-L40	CASQUILLO Ø10XØ16X4,5	LIMIT BUSHING Ø10XØ16X4.5
41	SP-39i-L41	SOPORTE BRAZO DERECHO	RIGHT ROCKER ARM BRACKET
42	SP-39i-L42	TAPA SOPORTE BRAZO DERECHO	RIGHT CAP OF ROCKER ARM
43	SP-39i-L43	TUERCA M6	HEXAGON NUTS M6
44	SP-39i-L44	BALANCIN	FLIP ARM
45	SP-39i-L45	MANGO CARCASA DELANTERA	HANDLE OF FRONT COVER
46	SP-39i-L46	TAPA SOPORTE BRAZO IZQUIERDO	LEFT CAP OF ROCKER ARM
47	SP-39i-L47	SOPORTE BRAZO IZQUIERDO	LEFT ROCKER ARM BRACKET
48	SP-39i-L48	CARCASA DELANTERA	FRONT COVER OF SHELL
49	SP-39i-L49	BRAZO TRANSPORTE DERECHO	RIGHT FLIP ARM
50	SP-39i-L50	BRAZO TRANSPORTE IZQUIERDO	LEFT FLIP ARM
51	SP-39i-L51	TORNILLO M6X10	INNER HEXAGON SCREW M6X10
52	SP-39i-L52	TORNILLO M6X20	INNER HEXAGON SCREW M6X20
53	SP-39i-L53	VARILLA	TROLLEY
54	SP-39i-L54	MANGO	FLIP HANDLE
55	SP-39i-L55	TAPON	INVERTER BASE WAD KP
60	SP-39i-L60	TORNILLO M6X12	HEXAGON FLANGE BOLTS M6X12
61	SP-39i-L61	JUNTA Ø6	GASKET Ø6
62	SP-39i-L62	ARANDELA Ø6	FLAT WASHER Ø6
63	SP-39i-L63	TORNILLO ST3,5X13	TAPPING SCREW ST3.5X13

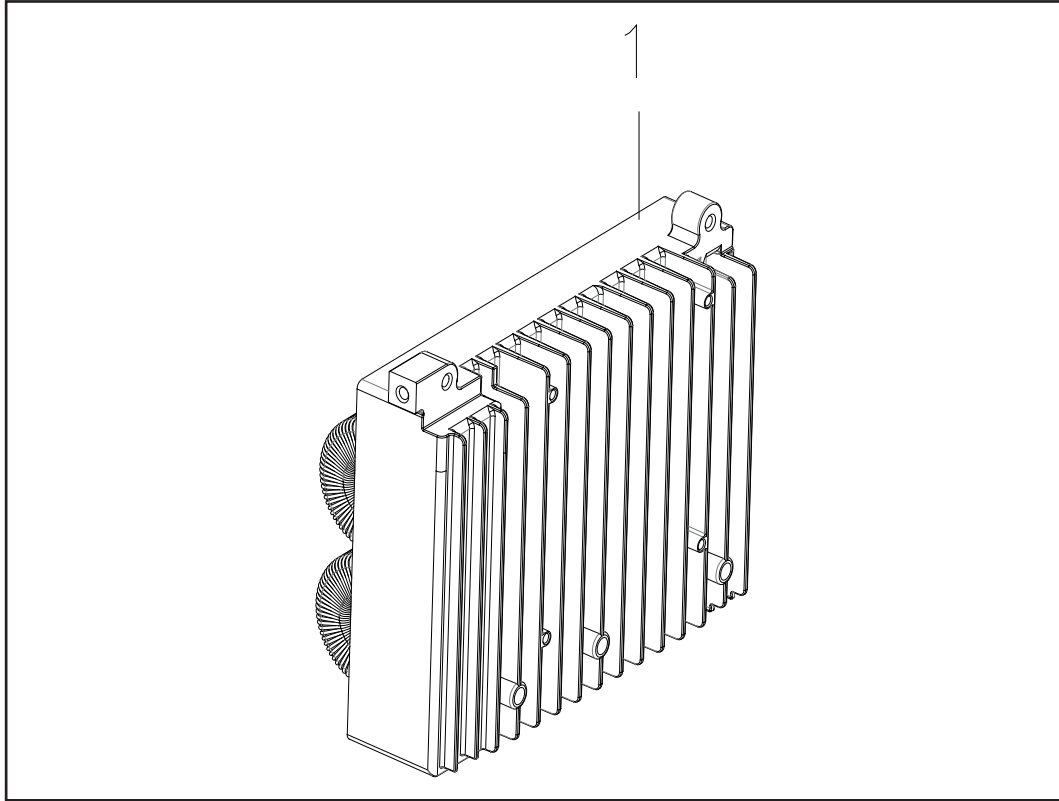

Nº	REF.	DESCRIPCIÓN (ES)	DESCRIPTION (EN)
1	SP-39i-M01	PLACA INVERTER	INVERTER

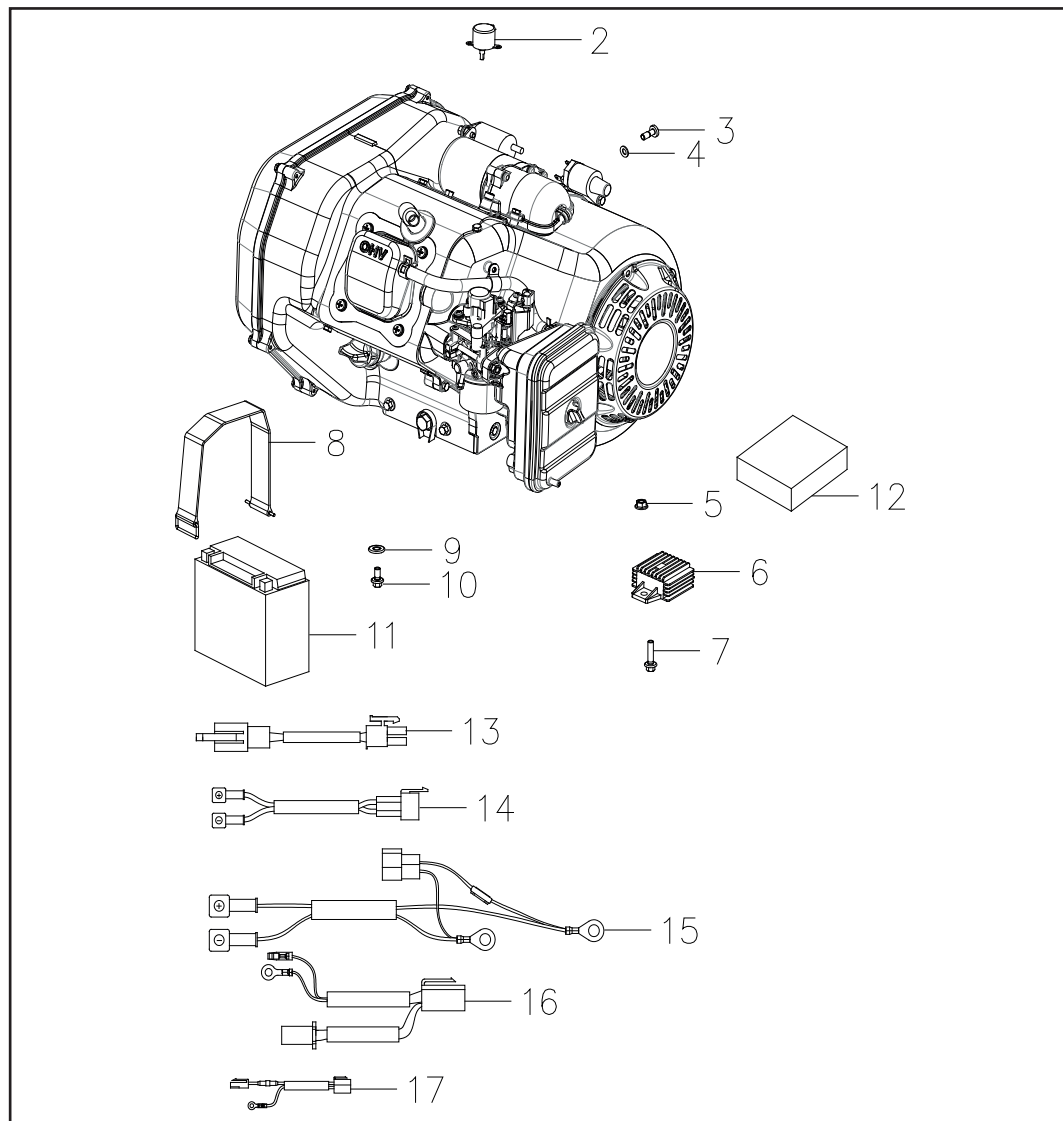

Nº	REF.	DESCRIPCIÓN (ES)	DESCRIPTION (EN)
2	SP-39i-N02	MOTOR CARBURADOR	STEPPER MOTOR ASSY
3	SP-39i-N03	TORNILLO M5X10	SCREW M5X10
4	SP-39i-N04	ARANDELA Ø5	WASHER Ø5
5	SP-39i-N05	TUERCA M6	FLANGE NUT M6
6	SP-39i-N06	REGULADOR CARGA BATERIA	REGULATOR
7	SP-39i-N07	TORNILLO M6X16	FLANGE BOLT M6X16
8	SP-39i-N08	SOPORTE BATERIA	BATTERY LAYER
9	SP-39i-N09	ARANDELA	EXTRA LARGE WASHER
10	SP-39i-N10	TORNILLO ST4,8X13	TAPPING SCREW ST4.8X13
11	SP-BAT-6.5	BATERIA 12V 6,5AH	BATTERY 12V 6.5AH
12	SP-39i-N12	MODULO CONTROL REMOTO ATS	REMOTE CONTROL MODULE OF ATS
13	SP-39i-N13	CABLE MOTOR CARBURADOR	STEPPER MOTOR CORD
14	SP-39i-N14	CABLE SALIDA INVERTER	INVERTER OUTPUT WIRE
15	SP-39i-N15	CABLE BATERIA	BATTERY WIRE
16	SP-39i-N16	CABLE ARRANQUE ELECTRICO	E-START WIRE
17	SP-39i-N17	CABLE ELECTROIMAN	ELECTROMAGNET WIRE

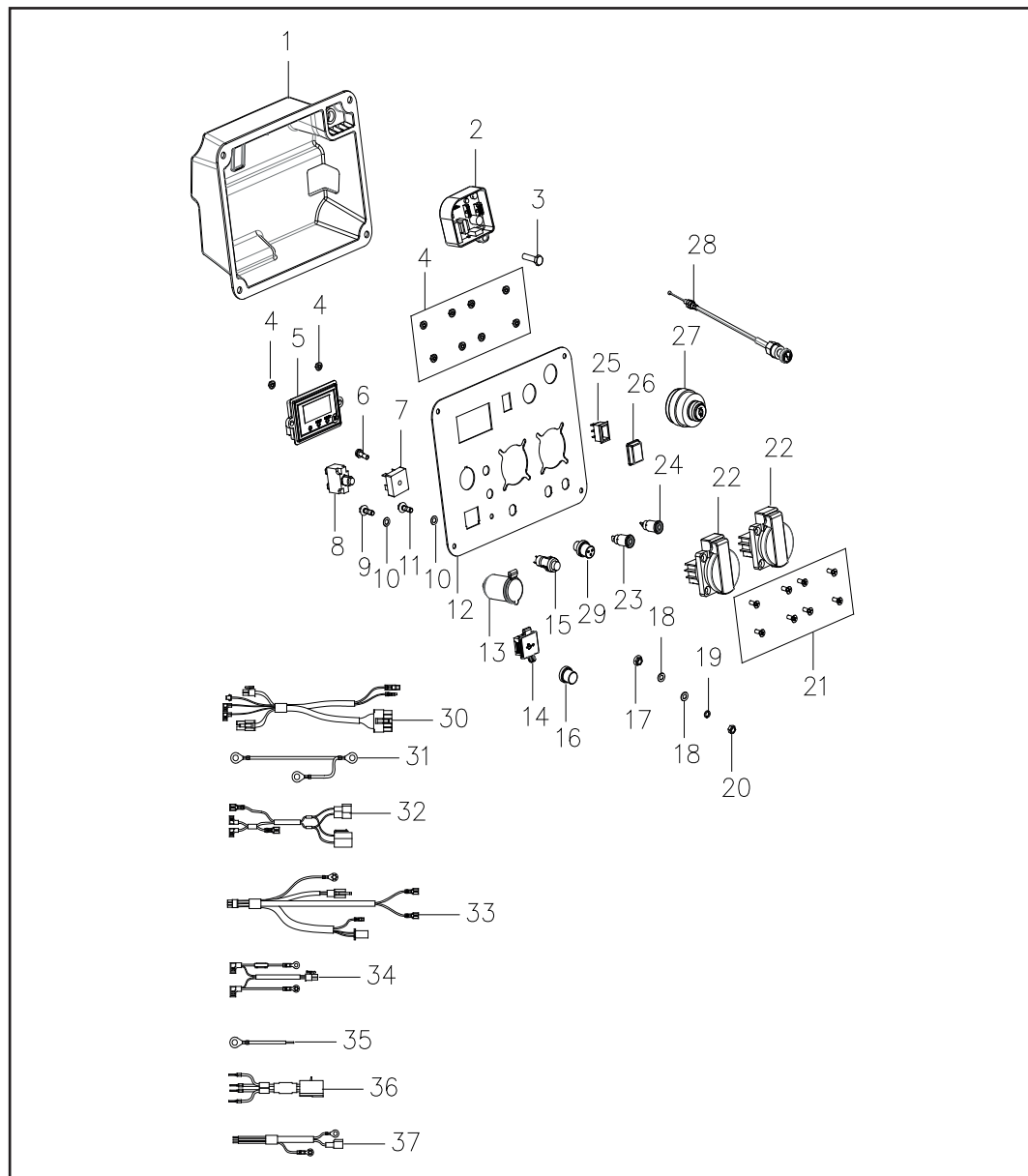

Nº	REF.	DESCRIPCIÓN (ES)	DESCRIPTION (EN)
1	SP-39i-001	CAJA PANEL DE CONTROL	PANEL BOX
2	SP-39i-002	CONTROLADOR ARRANQUE	IGNITION CONTROLLER
3	SP-39i-003	TORNILLO ST4,8X16	TAPPING SCREW ST4.8X16
4	SP-39i-004	BASE ROSCA M4	FLANGE NUT M4
5	SP-39i-005	DIGITAL DISPLAY	MULTIFUNCTION DIGITAL DISPLAY
6	SP-39i-006	TORNILLO M5X16	SCREW M5X16
7	SP-PC-RECTI-3502	RECTIFICADOR KBPC3502	RECTIFIER KBPC3502
8	SP-PC-OVER-10A	PROTECTOR SOBRECARGA 10A CC	OVERLOAD PROTECTOR 10A
9	SP-39i-009	TORNILLO M5X16	FLANGE BOLT M5X16
10	SP-39i-010	ARANDELA Ø5	WASHER Ø5
11	SP-39i-011	TORNILLO M5X8	SCREW M5X8
12	SP-39i-012	PLACA PANEL DE CONTROL	PANEL COMPONENTS
13	SP-39i-013	TOMA MECHERO	CIGAR LIGHTER SOCKET
14	SP-39i-014	ENTRADA USB	DOUBLE USB
15	SP-39i-015	BOTON RESET	RESET SWITCH
16	SP-PC-OVER-PROTEC	PROTECTOR LLUVIA	WATER-PROOF CAP OF OVERLOAD PROTECTOR
17	SP-39i-017	TUERCA M5	FLANGE NUT M5
18	SP-39i-018	ARANDELA Ø5	FLAT WASHER Ø5
19	SP-39i-019	ARANDELA GLOVER Ø5	SPRING WASHER Ø5
20	SP-39i-020	TUERCA M5	FLANGE NUT M5
21	SP-39i-021	TORNILLO M4X12	SCREW M4X12
22	SP-PC-BASE-SCH-16A-IP54	BASE ENCHUFE SHUCKO 16A IP54 230V	EUROPEAN SOCKET IP54
23	SP-39i-023	ENCHUFE NEGRO	SECURE PANEL SOCKET (BLACK)
24	SP-39i-024	ENCHUFE ROJO	SECURE PANEL SOCKET (RED)
25	SP-PC-SWITCH-C	INTERRUPTOR ON/OFF	BOAT SWITCH
26	SP-PC-SWITCH-CUBIERTA	PROTECTOR LLUVIA INTERRUPTOR	WATER-PROOF CAP OF BOAT SWITCH
27	SP-PC-KEYS-H	BOMBIN ARRANQUE	BOAT SWITCH KCD4
28	SP-39i-028	CABLE ESTARTER	THROTTLE ROPE ASSEMBLY
29	SP-39i-029	INTERRUPTOR ARRANQUE ELECTRICO	ELECTRIC STARTER SWITCH
30	SP-39i-030	CABLE INVERTER	INVERTER WIRE
31	SP-39i-031	CABLE TOMA DE TIERRA	PANEL EARTH WIRE
32	SP-39i-032	CABLE ENTRADA ENCHUFE DC	DC SOCKET INPUT WIRE
33	SP-39i-033	CABLE CONTROL ARRANQUE	IGNITION CONTROLLER WIRE
34	SP-39i-034	CABLE ENCHUFE DC	DC SOCKET WIRE
35	SP-39i-035	ENCHUFE TOMA DE TIERRA	SOCKET EARTH WIRE
36	SP-39i-036	CABLE ENCHUFE AC	AC SOCKET WIRE (EU)
37	SP-39i-037	CABLE ATS	ATS WIRE

WIRING DIAGRAM

BXGNi4000E (230V)

