



HOW TO ASSEMBLE

SKYLIGHT / RUBICON SHED SHELF KIT

Compatible with Palram - Canopia's

Skylight™ 4x6 / 1.2x1.8 | 6x3 / 2x1 | 6x5 / 2x1.5
6x8 / 2x2.3 | 6x10 / 2x3 | 6x12 / 2x3.8

Rubicon™ 6x5 / 2x1.5 | 6x8 / 2x2.3 | 6x10 / 2x3
6x12 / 2x3.8

IMPORTANT!

Please read these instructions carefully before starting assembly.
Keep these instructions in a safe place for future reference.



HAVE A CONCERN? WE CAN HELP.

Before returning your purchase:

You didn't find what you
were looking for?
We can help at
[**canopia.shop/support**](https://canopia.shop/support).

Still can't find what you
are looking for?
Please see next page for
local customer care.

HABEN SIE BEDENKEN? WIR KÖNNEN HELFEN.

Bevor Sie Ihren Kauf zurücksenden:

Haben Sie nicht gefunden,
wonach Sie gesucht haben?
Unter [**canopia.shop/support**](https://canopia.shop/support)
können wir helfen.

Sie haben noch nicht
gefunden wonach Sie suchen?
Auf der nächsten Seite
finden Sie den Kontakt zu
unserem lokalen Kundendienst.

TIENE ALGUNA INQUIETUD? PODEMOS AYUDARLE.

Antes de retornar su compra:

No encontró lo que
estaba buscando?
Podemos ayudarle en
[**canopia.shop/support**](https://canopia.shop/support).

Aún no encontró lo que buscaba?
Por favor vea en la siguiente
página el Servicio Local al Cliente.

UN SOUCI? UNE QUESTION? NOUS POUVONS VOUS AIDER.

Avant de renvoyer ce produit:

Vous n'avez pas trouvé
ce que vous cherchez ?
Nous pouvons vous aider sur
[**canopia.shop/support**](https://canopia.shop/support).

Insatisfait/e ou sans réponse ?
Merci de contacter notre Service
Client local ci-dessous.





WE ARE HERE TO HELP

For general questions: canopia.com/contact-us

NORWAY • SWEDEN • ARGENTINA • GREECE • GREENLAND • ICELAND • ESTONIA • JAPAN • LATVIA • LITHUANIA
MAURITIUS • MEXICO • ROMANIA • RUSSIA • TURKEY • UZBEKISTAN • UKRAINE • SWAZILAND • KOREA

+972-4-848-6816 | customer.service@palram.com

USA	CANADA	HUNGARY • SLOVAKIA
877-627-8476 generalsupport@poly-tex.com	905-5646007 sales@footprintproducts.com	+420-493-523-523 servis@garland.cz
UNITED KINGDOM • IRELAND	GERMANY	NEW ZEALAND
01302-380775 customer.serviceUK@palram.com	0180-522-8778 customer.serviceDE@palram.com	0800 800 880 customer.service@palram.com
FRANCE • BELGIUM	ISRAEL	DENMARK
+33-169-791-094 customer.serviceFR@palram.com	04-848-6800 customer.service@palram.com	07-575 42 70 post@nshnordic.com
ITALY • NETHERLANDS • PORTUGAL • SPAIN	AUSTRIA • LUXEMBURG • LIECHTENSTEIN	SOUTH AFRICA
+33-169-791-094 customer.serviceFR@palram.com	+49-180-522-8778 customer.serviceDE@palram.com	011-397-7771 receptionza@palram.com
AUSTRALIA	AUSTRALIA - GREENHOUSES	CROATIA • SLOVENIA
03-9219-4444 salesvic@palram.com	03-9544-6-999 info@mazedistribution.com.au	0599-37-057 info@ms-viscom.com
CZECH REPUBLIC	SWITZERLAND	POLAND
0493-523-523 servis@garland.cz	062-287-33-77 info@ritter.ch	Infolinia: 801-011-929 22-349-93-36 kontakt@ogrodosfera.pl
CYPRUS	FINLAND	
0224-971-13 alpaco@alpacodomica.com www.alpacodomica.com	Neuvonta: 09-6866720 Tuki / Varaosat: 050-3715350 www.horizontenterprises.fi tuki@horizontenterprises.fi	

SAFETY ADVICE

- Dispose of all plastic bags safely – keep them away from children’s reach.
- Keep children away from the assembly area.
- When using a stepladder or power tools, make sure that you are following the manufacturer’s safety advice.
- Some parts may have sharp edges. Please be careful when handling components.

IMPORTANT RECOMMENDATIONS

- These instructions are compatible with Palram Canopia’s Skylight™ 4x6 / 1.2x1.8 | 6x3 / 2x1 | 6x5 / 2x1.5 | 6x8 / 2x2.3 | 6x10 / 2x3 | 6x12 / 2x3.8 Rubicon™ 6x5 / 2x1.5 | 6x8 / 2x2.3 | 6x10 / 2x3 | 6x12 / 2x3.8
- Please carry out the steps in the order set out in these instructions.
- Keep these instructions in a safe place for future reference.

TOOLS & EQUIPMENT



Work Gloves



Wrench
10 mm | 13/32”



Philips Head
Screwdriver

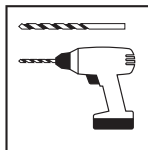

Electric Drill With Drill Bit
7 mm | 9/32”

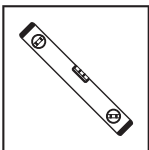

Spirit Level

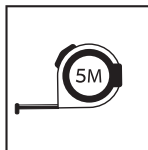

Tape Measure

BEFORE ASSEMBLY

1. Please read these instructions carefully before you start to assemble this product.
2. Some of the steps may require the assistance of a second person.
3. Sort the parts and check according to the contents parts list.
4. Following are a number of illustrations depicting possibilities for mounting the SkyLight / Rubicon shelf on all Palram SkyLight / Rubicon Shed sizes.
5. It is highly recommended to plan the assembly prior to starting, according to one of the following options:

4x6 / 1.2x1.8

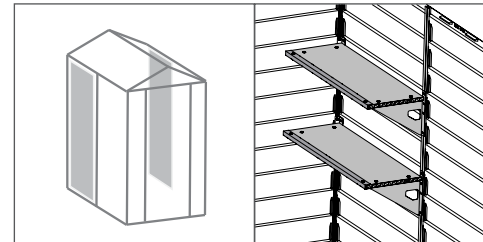

6x3 / 2x1

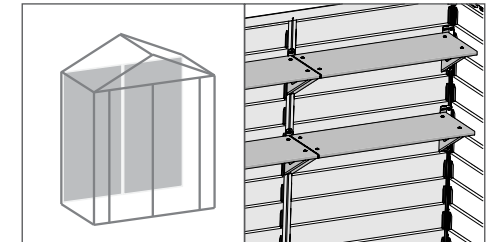

6x5 / 2x1.5 | 6x8 / 2x2.3 | 6x10 / 2x3 | 6x12 / 2x3.8

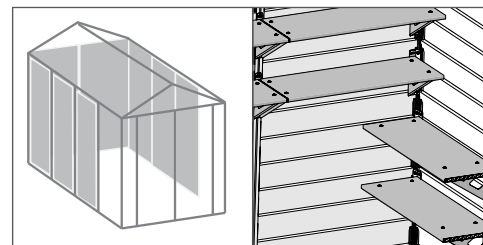

- Once you have chosen your preferable option please go to the appropriate page in the Assembly Instructions.

DURING ASSEMBLY

- Panel (#9633) is not pre-drilled; therefore you must drill the holes with accordance to your chosen option.
- Metal plate (#8075) is used for mounting the shelf onto either one of the shed's corners. If you did not choose this option, there is no need to use this part; keep it for future use if needed.
- Tighten all screws when completing assembly.

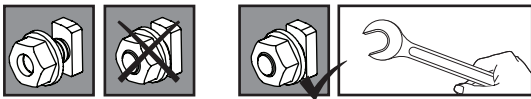

- When encountering these icons, you are requested to either keep the screws slightly loose or to fully tighten the screws.

ATTENTION!

- Do not mount more than 2 shelves onto one panel.

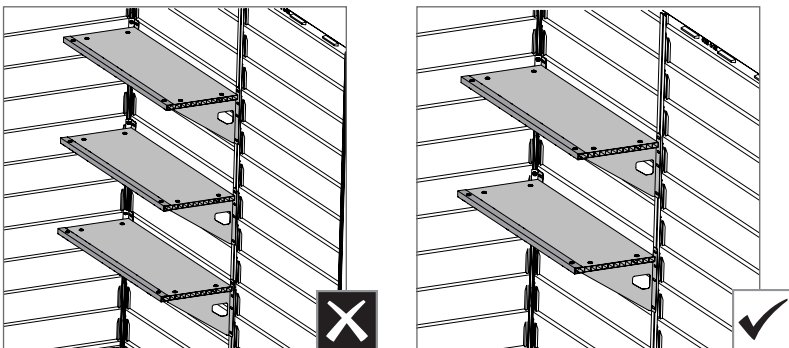

- Do not mount more than 4 shelves on a single wall.
- Under any circumstance do not mount more than 10 shelves per shed.
- A single shelf can carry up to **30 kg (66 lbs)**.

4 OPTIONS

Option 1:

Mounting the shelf in the middle of the side wall

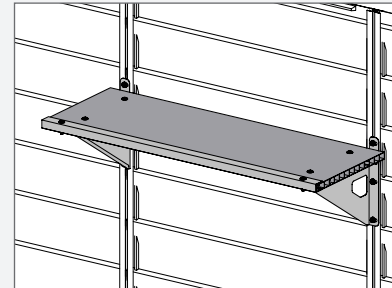

(Not suitable for 4x6 / 1.2x1.8 shed)

Option 2:

Mounting the shelf where the shelf's left side connects with the shed's corner

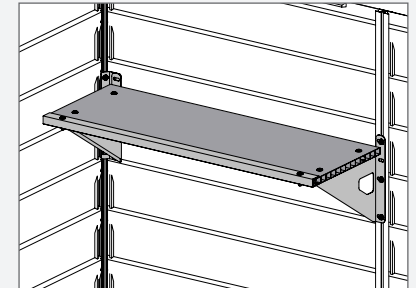

Option 3:

Mounting the shelf where the shelf's right side connects with the shed's corner

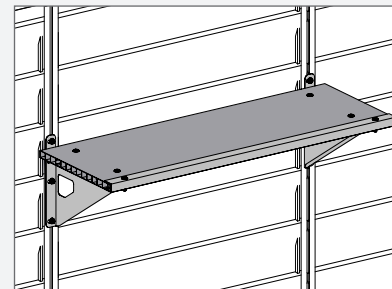

Option 4:

Mounting the shelf side by side (only at the shed's rear wall)

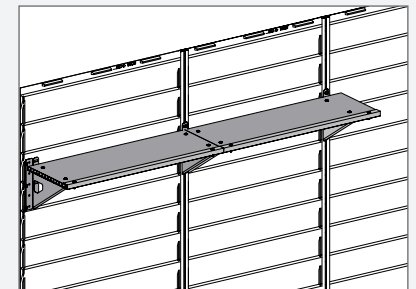

(Not suitable for 4x6 / 1.2x1.8 shed)

CONSEILS DE SECURITE

- Jetez précautionneusement tous les sacs plastiques – tenez-les hors de portée des enfants.
- Tenez les enfants à distance de la zone de montage.
- Si vous utilisez un escabeau ou des outils électriques, assurez-vous de respecter les consignes de sécurité du fabricant.
- Certaines pièces pourraient avoir des arêtes tranchantes. Veuillez agir avec prudence lors de la manipulation de l'un des composants.

RECOMMANDATIONS IMPORTANTES

- Ces instructions ne sont compatibles qu'avec le Gazebo du jardin Palram Canopia's Skylight™ 4x6 / 1.2x1.8 | 6x3 / 2x1 | 6x5 / 2x1.5 | 6x8 / 2x2.3 | 6x10 / 2x3 | 6x12 / 2x3.8
Rubicon™ 6x5 / 2x1.5 | 6x8 / 2x2.3 | 6x10 / 2x3 | 6x12 / 2x3.8
- Veuillez suivre les étapes dans l'ordre indiqué dans ces instructions.
- Conservez ces instructions en lieu sûr pour référence ultérieure.

OUTILS ET ÉQUIPEMENT

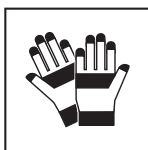

Gants de travail

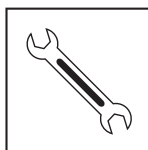

Clé
10 mm | 13/32"



Tournevis cruciforme

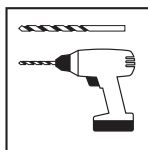

Perceuse filaire avec foret
7 mm | 9/32"

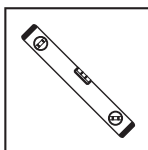

Niveau

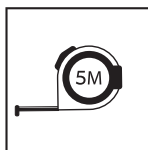

Mètre

AVANT LE MONTAGE

1. Veuillez lire attentivement ces instructions avant de commencer l'assemblage de ce produit.
2. Certaines étapes nécessitent l'aide d'une deuxième personne.
3. Triez les pièces et vérifiez le contenu selon la liste des composants.
4. Vous trouverez ci-dessous un certain nombre d'illustrations représentant les différentes possibilités de monter l'étagère sur toutes les tailles de Skylight / Rubicon Palram pour remise.
5. Il est fortement recommandé de planifier l'assemblage avant de le commencer, selon les options suivantes:

4x6 / 1.2x1.8

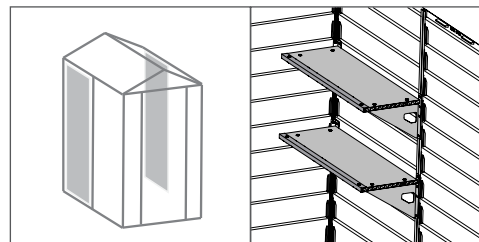

6x3 / 2x1

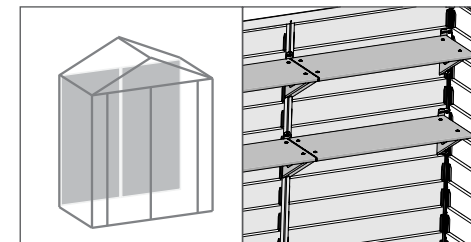

6x5 / 2x1.5 | 6x8 / 2x2.3 | 6x10 / 2x3 | 6x12 / 2x3.8

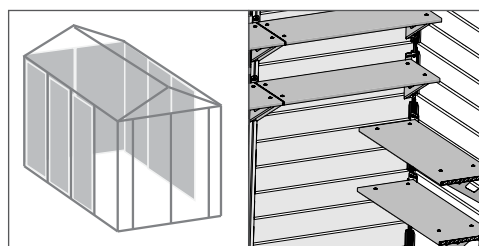

- Une fois que vous avez choisi votre option privilégiée, veuillez vous rendre à la page appropriée dans les instructions d'assemblage.

DURANT L'ASSEMBLAGE

- Le panneau (# 9633) n'est pas pré-percé ; vous devrez donc percer les trous conformément à l'option que vous avez choisie.
- La plaque métallique (# 8075) est utilisée pour le montage de l'étagère sur l'un des coins de la remise. Si vous n'avez pas choisi cette option, il ne sera pas nécessaire de l'utiliser; conservez-la pour une utilisation future en cas de besoin.
- En fin d'assemblage, veillez à bien resserrer toutes les vis.



- Lorsque vous rencontrez ces icônes, vous devez soit laisser les vis assez lâches, soit les serrer jusqu'au bout.

ATTENTION!

- Ne montez pas plus de deux étagères sur un panneau.

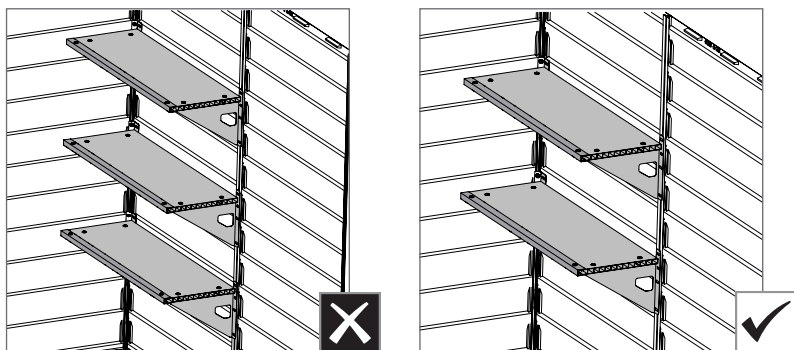

- Ne montez pas plus de 4 étagères sur un seul mur.
- Ne montez jamais plus de 10 étagères par remise.
- Une seule étagère peut supporter jusqu'à **30 kg (66 lb)**.

4 OPTIONS

Option n ° 1:

Montage de l'étagère au milieu de la paroi latérale

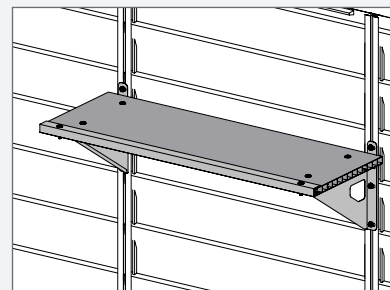

(Ne convient pas aux remises de taille 4x6 / 1.2x1.8)

Option n ° 2:

Montage de l'étagère à l'endroit où le côté gauche de l'étagère se connecte avec le coin de la remise

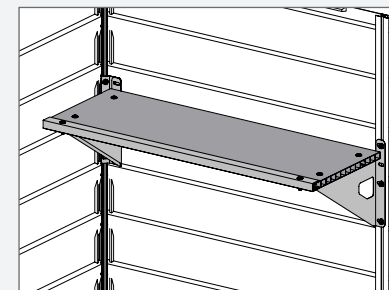
**Option n ° 3:**

Montage de l'étagère à l'endroit où le côté droit de l'étagère se connecte avec le coin de la remise

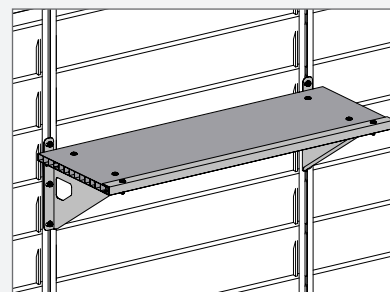
**Option n ° 4:**

Montage de l'étagère côté à côté (uniquement à la paroi arrière de la remise)

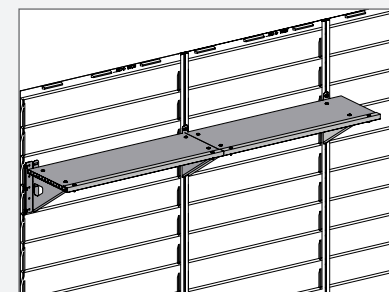

(Ne convient pas aux remises de taille 4x6 / 1.2x1.8)

SICHERHEITSHINWEISE

- Entsorgen Sie die Plastikbeutel vorschriftsgemäss – und achten Sie darauf, dass sie nicht in Reichweite von Kindern kommen.
- Halten Sie Kinder während des Aufbaus vom Carport fern.
- Wenn Sie eine Stufenleiter oder Elektrowerkzeuge benutzen, achten Sie darauf, die Sicherheitshinweise des Herstellers zu befolgen.
- Einige Teile haben scharfe Kanten. Bitte seien Sie vorsichtig im Umgang mit den einzelnen Bestandteilen.

WICHTIGE HINWEISE

- Diese Anweisungen sind nur gültig für Palram Canopia's SkyLight™ 4x6 / 1.2x1.8 | 6x3 / 2x1 | 6x5 / 2x1.5 | 6x8 / 2x2.3 | 6x10 / 2x3 | 6x12 / 2x3.8
Rubicon™ 6x5 / 2x1.5 | 6x8 / 2x2.3 | 6x10 / 2x3 | 6x12 / 2x3.8
- Bitte führen Sie die einzelnen Schritte in der in dieser Anleitung angegebenen Reihenfolge durch.
- Bewahren Sie diese Anleitung für späteren Gebrauch sicher auf.

WERKZEUGE & AUSRÜSTUNG



Arbeitshandschuhe

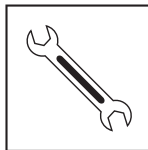

Schraubenschlüssel
10 mm | 13/32"



Kreuzschlitzschraubendreher

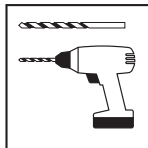

Bohrmaschine mit Bohrer
7 mm | 9/32"

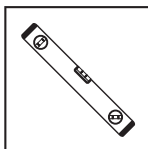

Wasserwaage

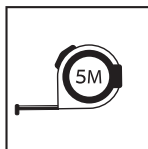

Maßband

VOR DEM ZUSAMMENBAU

1. Bitte lesen Sie diese Anleitung aufmerksam durch, bevor Sie mit der Montage dieses Regals beginnen.
2. Einige der Arbeitsgänge machen es notwendig, dass eine zweite Person zur Hand geht
3. Sortieren Sie die einzelnen Teile und gleichen Sie sie mit der Inhaltsliste ab.
4. Im Folgenden finden Sie einige Illustrationen, welche die Montagemöglichkeiten für das SkyLight / Rubicon -Regal auf den Palram SkyLight / Rubicon Gartenhäuschen jeder Größe darstellen.
5. Es wird dringend empfohlen, den Aufbau je nach einer der folgenden Möglichkeiten zu planen, bevor damit begonnen wird:

4x6 / 1.2x1.8

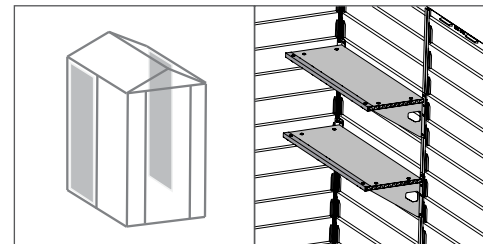

6x3 / 2x1

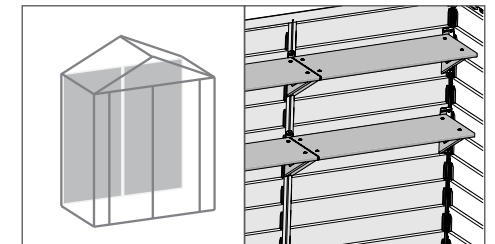

6x5 / 2x1.5 | 6x8 / 2x2.3 | 6x10 / 2x3 | 6x12 / 2x3.8

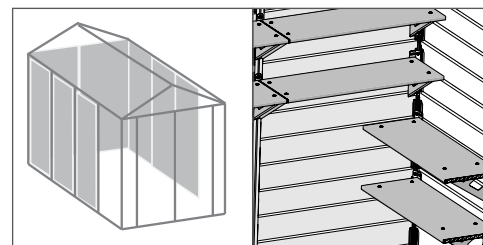

- Wenn Sie sich für eine Möglichkeit entschieden haben, schlagen Sie bitte die entsprechende Seite der Montageanleitung auf.

WÄHREND DER MONTAGE

- Das Paneel (**Nr.9633**) wurde nicht vorgebohrt; deshalb müssen Sie die Löcher entsprechend der von Ihnen gewählten Option bohren.
- Die Metallplatte (**Nr.8075**) wird dazu verwendet, das Regal auf eine der Ecken des Gartenhauses zu montieren. Wenn Sie diese Option nicht gewählt haben, benötigen Sie die Platte nicht; bewahren Sie sie für eventuellen zukünftigen Bedarf auf.
- Ziehen Sie bei Beendigung des Aufbaus alle Schrauben fest.



- Wenn Sie auf diese Symbole stoßen, müssen Sie die Schrauben entweder leicht locker lassen oder vollständig anziehen.

VORSICHT!

- Montieren Sie nicht mehr als 2 Regale an ein Paneel.

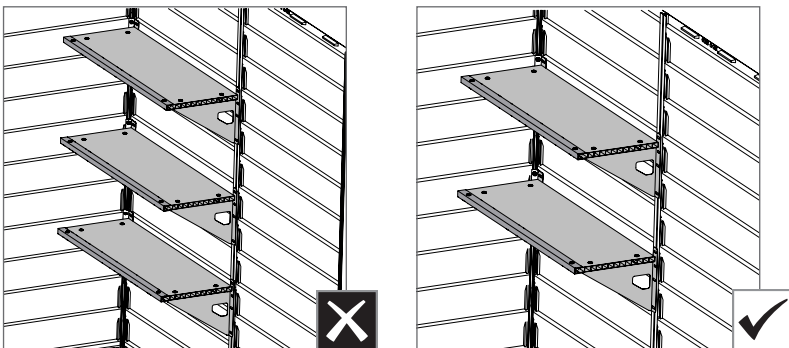

- Montieren Sie nicht mehr als 4 Regale an eine einzige Wand.
- Montieren Sie auf keinen Fall mehr als 10 Regale pro Gartenhaus.
- Ein Regal kann bis zu **30 kg tragen (66 lbs)**.

4 MÖGLICHKEITEN

Möglichkeit Nr.1:

Das Regal in der Mitte der Seitenwand anbringen

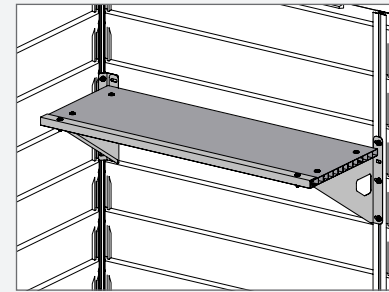

(Nicht geeignet für das 4x6 / 1.2x1.8 Gartenhaus)

Möglichkeit Nr.2:

Das Regal so montieren, dass sich seine linke Seite in der Ecke des Gartenhauses befindet

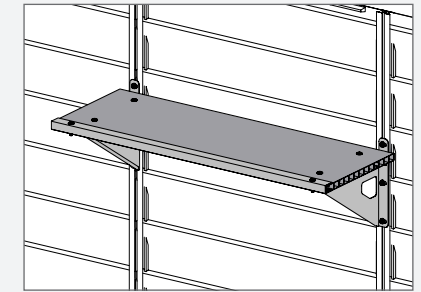

Möglichkeit Nr.3:

Das Regal so montieren, dass sich seine rechte Seite in der Ecke des Gartenhauses befindet

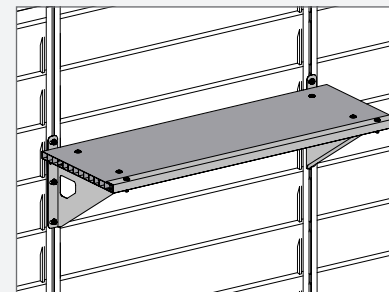

Möglichkeit Nr.4:

Das Regal seitlich anbringen (nur an der Rückwand des Gartenhauses)

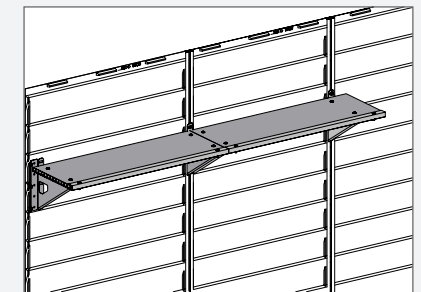

(Nicht geeignet für das 4x6 / 1.2x1.8 Gartenhaus)

CONSEJOS DE SEGURIDAD

- Tire todas las bolsas de plástico con seguridad; manténgalas fuera del alcance de los niños pequeños.
- Mantenga a los niños lejos del área de montaje.
- Cuando utilice una escalera de mano o herramientas eléctricas, asegúrese de seguir los consejos de seguridad del fabricante.
- Algunas piezas pueden tener bordes afilados. Por favor, tenga cuidado al manipular los componentes.

INFORMACIÓN IMPORTANTE

- Estas instrucciones son compatibles con la serie de Palram-Canopia Skylight™ 4x6 / 1.2x1.8 | 6x3 / 2x1 | 6x5 / 2x1.5 | 6x8 / 2x2.3 | 6x10 / 2x3 | 6x12 / 2x3.8 Rubicon™ 6x5 / 2x1.5 | 6x8 / 2x2.3 | 6x10 / 2x3 | 6x12 / 2x3.8
- Siga los distintos pasos en el mismo orden de las instrucciones.
- Guarde las instrucciones en un lugar seguro para poder consultarlas en el futuro.

HERRAMIENTAS Y EQUIPOS



Guantes de trabajo

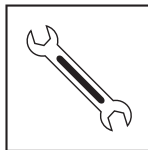

Llave
10 mm | 13/32"

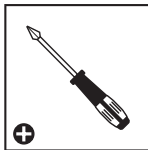

Destornillador de
cabeza Philips

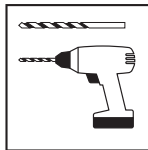

Taladro eléctrico con broca o mecha
7 mm | 9/32"

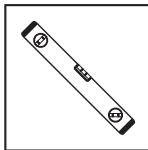

Regla de nivel

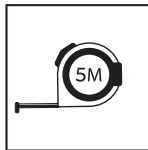

Cinta métrica

ANTES DEL ENSAMBLAJE

1. Por favor, lea estas instrucciones cuidadosamente antes de comenzar a montar este producto.
2. Algunos de los pasos pueden requerir ayuda de una segunda persona.
3. Ordene las piezas y compruébelas usando la lista de contenidos.
4. A continuación se muestra una serie de ilustraciones que muestran las posibilidades para montar la estantería Skylight / Rubicon en todos los tamaños de cobertizos SkyLight / Rubicon.
5. Se recomienda encarecidamente planificar previamente el montaje antes de comenzar, siguiendo una de las siguientes opciones:

4x6 / 1.2x1.8

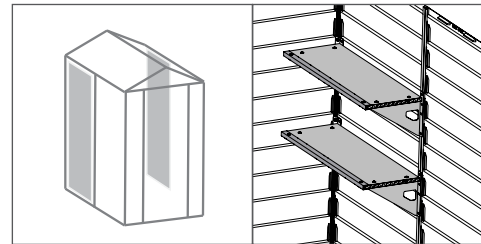

6x3 / 2x1

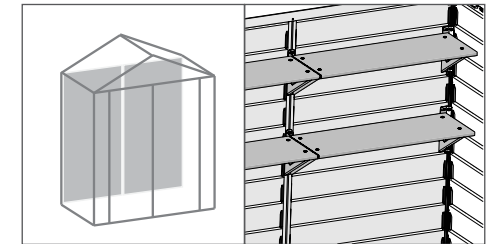

6x5 / 2x1.5 | 6x8 / 2x2.3 | 6x10 / 2x3 | 6x12 / 2x3.8

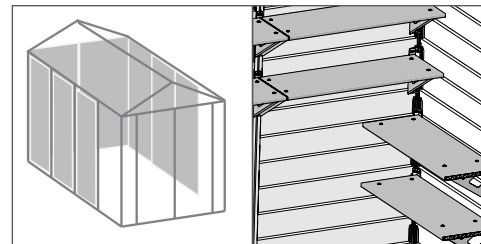

- Una vez que ha seleccionado su opción preferida, por favor, acuda a la página adecuada en las instrucciones de montaje.

DURANTE EL ENSAMBLAJE

- El panel n.º 9633 no viene pretaladrado; por lo tanto, deberá taladrar los agujeros según la opción que haya elegido.
- La placa metálica n.º 8075 se utiliza para montar la estantería en una de las dos esquinas del cobertizo. Si no ha elegido esta opción, no necesitará utilizar esta pieza; guárdela por si la utiliza en el futuro.
- Apriete todos los tornillos al finalizar el montaje.



- Cuando encuentre estos iconos, son para pedirle o bien que mantenga los tornillos sin apretar del todo o bien que apriete del todo los tornillos.

ATENCIÓN!

- No monte más de 2 estanterías en un panel.

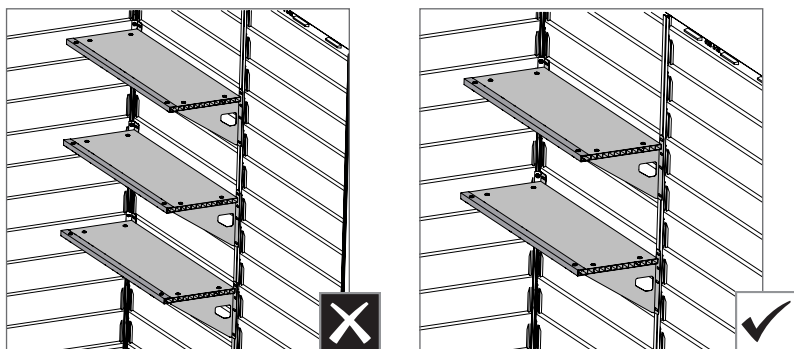

- No monte más de 4 estanterías en una única pared.
- Bajo ninguna circunstancia monte más de 10 estanterías por cobertizo.
- Una única estantería puede soportar hasta **30 kg (66 lb)**.

4 OPCIONES

Opción n.º 1:

Montar la estantería en el medio de la pared lateral

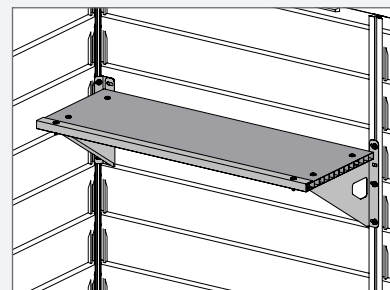

(No apto para el cobertizo 4x6 / 1.2x1.8)

Opción n.º 2:

Montar la estantería donde la parte izquierda del cobertizo se une con la esquina del cobertizo

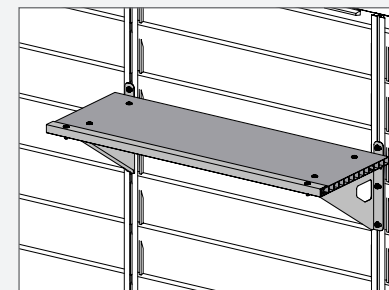

Opción n.º 3:

Montar la estantería donde la parte derecha del cobertizo se une con la esquina del cobertizo

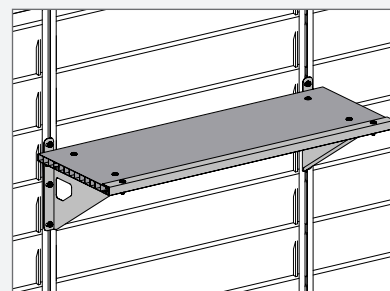

Opción n.º 4:

Montar la estantería una al lado de otra (solo en la pared trasera del cobertizo)

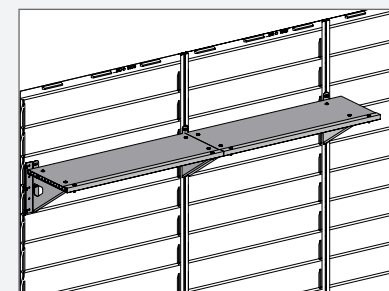

(No apto para el cobertizo 4x6 / 1.2x1.8)

לפני ההרכבה

1. נא לקרוא בקפידה את הוראות ההרכבה לפני תחילת הרכבת המוצר.
2. כמה מהצעדים עשויים לדרוש סיוע של אדם נוסף.
3. יש למיין את החלקים ולבדוק את כמויות אל מול רשימת התכולה.
4. להלן מספר איורים המציגים חלופות להתקנת המדף במחסני פלרם במידות שונות.
5. מומלץ לתכנן את ההתקנה הרצויה לפני תחילת ההרכבה בהתאם לאחת החלופות הבאות:

4x6 / 1.2x1.8

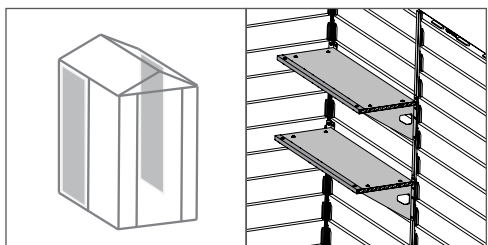

6x3 / 2x1

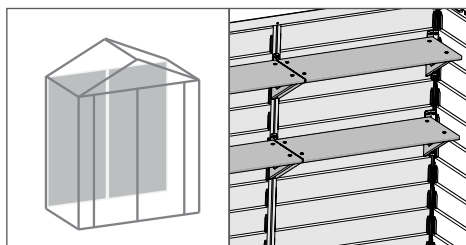

6x5 / 2x1.5 | 6x8 / 2x2.3 | 6x10 / 2x3 | 6x12 / 2x3.8

- לאחר שנבחרה אפשרות ההתקנה הרצויה, יש לעבור לעמוד המתאים בהוראות ההרכבה.

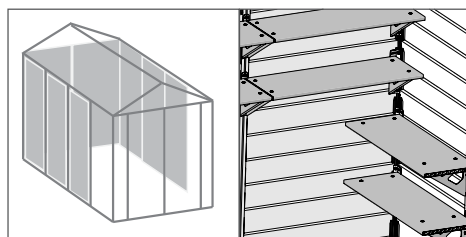

הצעת בטיחות

- נא להיפטר בבטחה משקיות הפלסטיק שבאריזה - להרחיק מהישג ידם של פעוטות.
- נא להרחיק ילדים קטנים מאזור ההתקנה.
- בשימוש בסולם או כל כלי עבודה חשמלי יש לעקוב אחר הוראות הבטיחות של היצרן.
- לחלקים מסוימים יש קצוות מתכת - נא לטפל בחלקים אלו בזהירות הנדרשת.

המלצות חשובות

- הוראות אלה תואמות לסדרת דאלאס של פלרם מבית CANOPIA:
 Skylight™ 4x6 / 1.2x1.8 | 6x3 / 2x1 | 6x5 / 2x1.5 | 6x8 / 2x2.3 | 6x10 / 2x3 | 6x12 / 2x3.8
 Rubicon™ 6x5 / 2x1.5 | 6x8 / 2x2.3 | 6x10 / 2x3 | 6x12 / 2x3.8
- נא לבצע את שלבי ההרכבה בסדר המוצג בהוראות אלה.
- נא לשמור את הוראות ההרכבה במקום בטוח לשימוש עתידי.

כלים וציוד

מפתח
10mm 13/32"

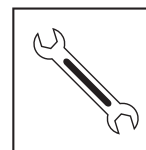

כפפות עבודה



מקדחה חשמלית כולל מקדחים
7mm 9/32"

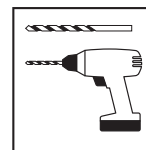

מברג פיליפס

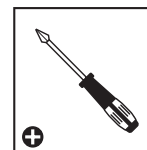

סרט מדידה

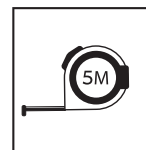

פלס מים

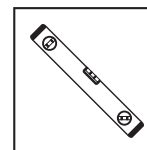

4 אפשרויות

אפשרות 2:

- התקנת מדף כשצידו השמאלי מתחבר אל פינת המחסן

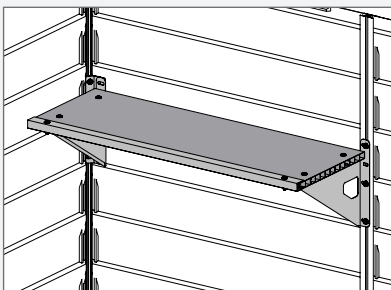

אפשרות 1:

- התקנת מדף באמצע קיר הצד

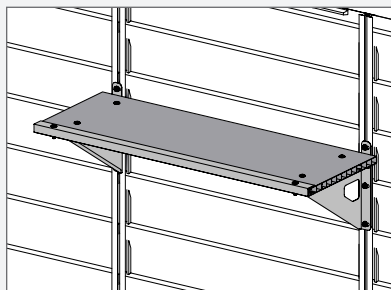

(לא רלוונטי למחסן 1.2x1.8 / 4x6)

אפשרות 4:

- התקנת מדף כשצידו הימני מתחבר אל פינת המחסן

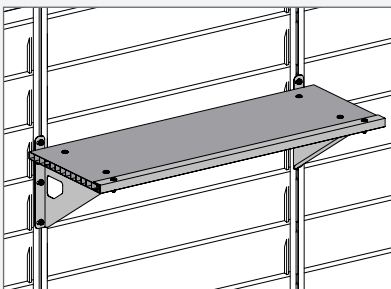

אפשרות 3:

- התקנת מדפים זה לצד זה (ניתן רק בקיר המחסן האחורי)

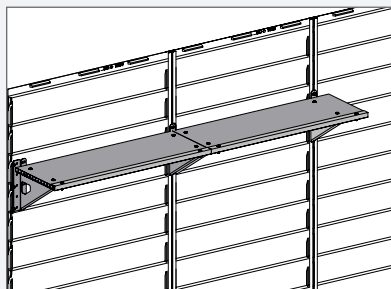

(לא רלוונטי למחסן 1.2x1.8 / 4x6)

במהלך ההרכבה

- בפנל (חלק מס' 9633) אין חורים מוכנים, לכן יש לקדוח חורים בהתאם לתצורת ההתקנה שנבחרה.
- לוחית המתכת (חלק מס' 8075) משמשת לקיבוע אל אחת מפינות המחסן. אם לא נבחרה תצורת התקנה זו, אין כל שימוש לחלק זה. יש לשמור אותו לשימוש עתידי אפשרי.
- נא להדק את כל הברגים בתום ההתקנה.



- כאשר מופיעים סמלים אלו, תתבקש לשמור על הברגים כשהם רופפים במקצת או להדק את הברגים עד הסוף.

שים לב!

- אין להתקין יותר משני מדפים על אותו הפנל.

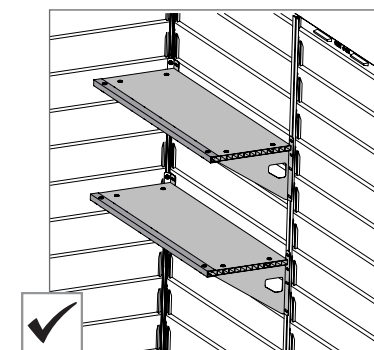
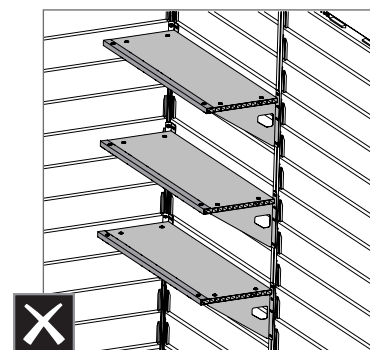

- אין להתקין יותר מארבעה מדפים על אותו הקיר.
- מכל סיבה שהיא אין להתקין יותר מעשרה מדפים במחסן כולו.
- מדף יכול לשאת עד 30 ק"ג.

CONSIGLIO DI SICUREZZA

- Smaltire tutti i sacchetti di plastica in modo sicuro - tenerli lontani dalla portata dei bambini.
- Tenere i bambini lontani dalla zona di assemblaggio.
- Quando utilizzate una scala o strumenti di potenza, assicuratevi di seguire i consigli di prudenza del produttore.
- Alcuni componenti possono avere dei bordi taglienti. Si prega di prestare attenzione quando si maneggiano i componenti.

RACCOMANDAZIONI IMPORTANTI

- Queste istruzioni sono compatibili con la serie di Palram-Canopia's: Skylight™ 4x6 / 1.2x1.8 | 6x3 / 2x1 | 6x5 / 2x1.5 | 6x8 / 2x2.3 | 6x10 / 2x3 | 6x12 / 2x3.8
Rubicon™ 6x5 / 2x1.5 | 6x8 / 2x2.3 | 6x10 / 2x3 | 6x12 / 2x3.8
- Si prega di andare passo passo nell'ordine indicato in queste istruzioni.
- Conservare le istruzioni in un luogo sicuro per un futuro riferimento.

STRUMENTI E ATTREZZATURE

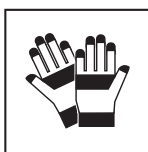

Guanti da lavoro

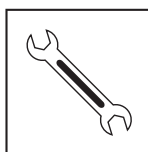

Chiave
10 mm | 13/32"

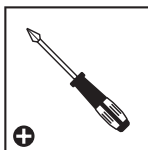

Cacciavite a croce

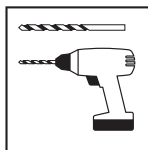

Trapano elettrico con punta
di trapano 7 mm | 9/32"

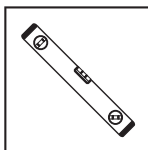

Righello di livello

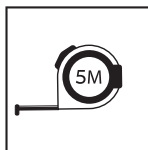

Nastro di misura

PRIMA DELL'ASSEMBLAGGIO

1. Si prega di leggere attentamente le istruzioni prima di iniziare a montare questo prodotto.
2. Alcuni passi possono richiedere l'assistenza di una seconda persona.
3. Ordinare i componenti e verificare in base alla lista di componenti.
4. Di seguito sono riportati una serie di illustrazioni raffiguranti le possibilità di montaggio dello Skylight / Rubicon Ripiano per tutte le dimensioni del Capannone Palram Skylight / Rubicon.
5. Si raccomanda di pianificare l'assemblaggio prima di iniziare, secondo una delle seguenti opzioni:

4x6 / 1.2x1.8

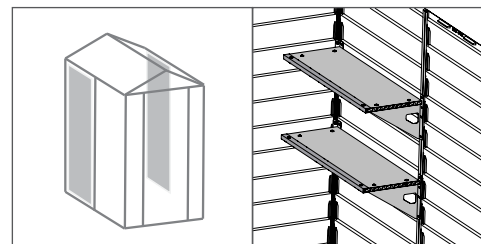

6x3 / 2x1

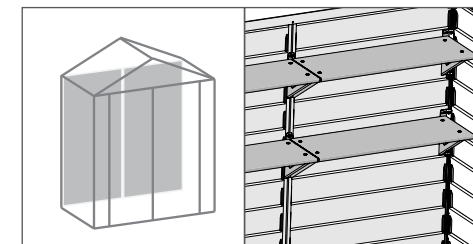

6x5 / 2x1.5 | 6x8 / 2x2.3 | 6x10 / 2x3 | 6x12 / 2x3.8

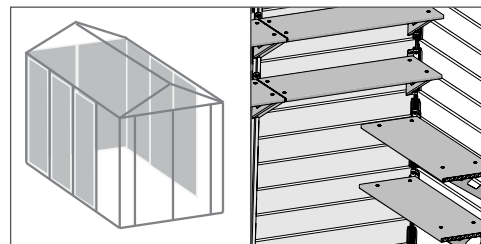

- Una volta scelta l'opzione preferibile andare alla pagina appropriata nelle istruzioni di Assemblaggio.

DURANTE L'ASSEMBLAGGIO

- Il pannello (# 9633) non è pre-forato, quindi è necessario fare i fori secondo l'opzione prescelta.
- Una piastra metallica (# 8075) viene utilizzata per il montaggio della mensola su uno di angoli del capannone. Se non si sceglie questa opzione, non vi è alcuna necessità di utilizzare questo componente; conservarlo per uso futuro, se necessario.
- Serra tutte le viti al momento di completare il montaggio.



- Quando si incontrano queste icone, è necessario mantenere le viti leggermente allentate o stringere completamente le viti.

ATTENZIONE!

- Non montare più di 2 ripiani su un pannello.

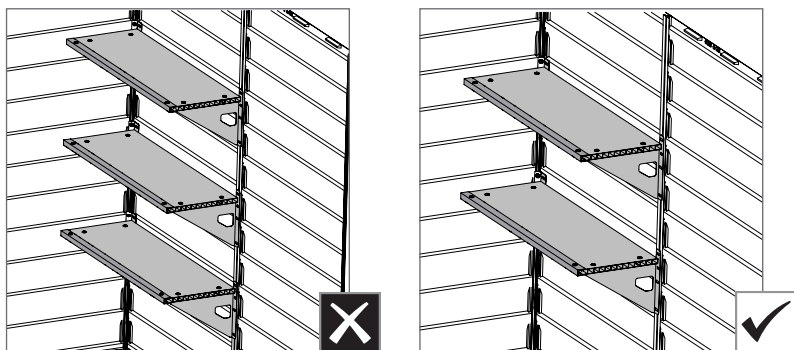

- Non montare più di 4 ripiani su un'unica parete.
- In ogni caso non montare più di 10 ripiani per capannone.
- Un singolo ripiano può tenere fino a **30 kg (66 lbs)**.

4 OPZIONI

Opzione #1:

Montaggio del ripiano al centro della parete laterale

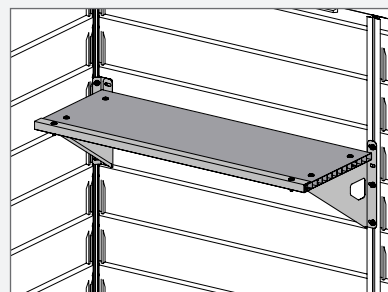

(Non adatto per capannone 4x6 / 1.2x1.8)

Opzione #2:

Montaggio del ripiano nel punto in cui il lato sinistro del ripiano si collega con l'angolo del capannone

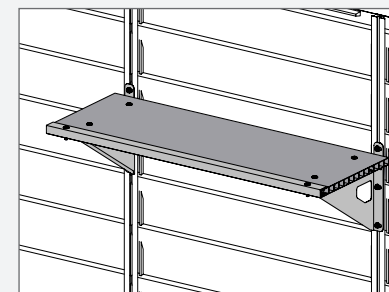
**Opzione #3:**

Montaggio del ripiano nel punto in cui il lato destro del ripiano collega con l'angolo del capannone

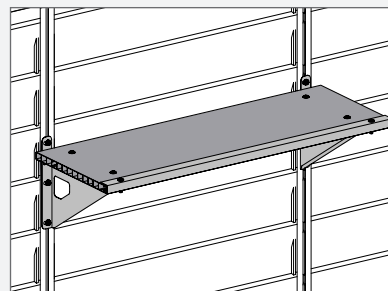
**Opzione #4:**

Montaggio del ripiano a fianco (solo nella parete posteriore del capannone)

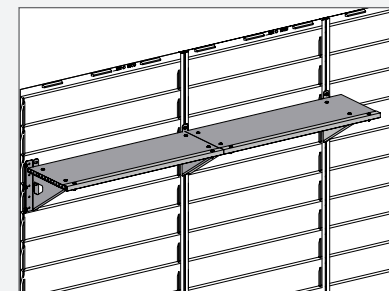

(Non adatto per capannone 4x6 / 1.2x1.8)

RADY DOT. BEZPIECZEŃSTWA

- Należy w bezpieczny sposób usunąć wszystkie plastikowe torby - trzymać je poza zasięgiem dzieci.
- Trzymaj dzieci z dala od miejsca wykonywania montażu.
- Podczas korzystania z drabiny lub elektronarzędzi, upewnij się, że postępujesz zgodnie z zaleceniami bezpieczeństwa producenta.
- Niektóre części posiadają ostre krawędzie. Należy zachować ostrożność podczas montażu.

WAŻNE ZALECENIA

- Te instrukcje są zgodne z Palram-Canopia Skylight™ 4x6 / 1.2x1.8 | 6x3 / 2x1 | 6x5 / 2x1.5 | 6x8 / 2x2.3 | 6x10 / 2x3 | 6x12 / 2x3.8 Rubicon™ 6x5 / 2x1.5 | 6x8 / 2x2.3 | 6x10 / 2x3 | 6x12 / 2x3.8
- przeprowadzanie poszczególnych etapów montażu w kolejności określonej w niniejszej instrukcji.
- Zachowaj tę instrukcję w bezpiecznym miejscu do przyszłego użytku.

NARZĘDZIA I SPRZĘT



Rękawice Robocze

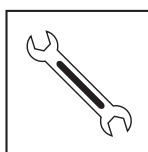

Klucz Płaski
10 mm | 13/32"



Śrubokręt
Krzyżakowy



Wiertarka Elektryczna z Wiertłem
7 mm | 9/32"

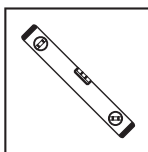

Poziomica

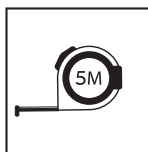

Miarka

W TRAKCIE MONTAŻU

1. Przed przystąpieniem do montażu produktu prosimy o uważne zapoznanie się z instrukcją.
2. Niektóre z działań mogą wymagać pomocy drugiej osoby.
3. Ułóż części i zweryfikuj ich kompletność na podstawie dostarczonej listy.
4. Poniżej znajdują się ilustracje przedstawiające możliwości montażu półki SkyLight / Rubicon we wszystkich rozmiarach domków ogrodowych SkyLight / Rubicon firmy Palram.
5. Zalecane jest zaplanowanie montażu przed jego rozpoczęciem zgodnie z jedną z poniższych opcji:

4x6 / 1.2x1.8

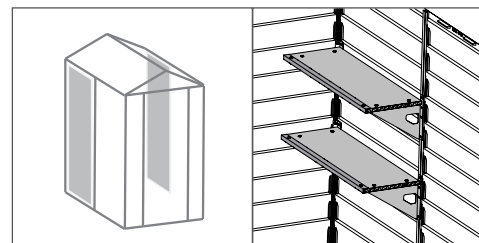

6x3 / 2x1

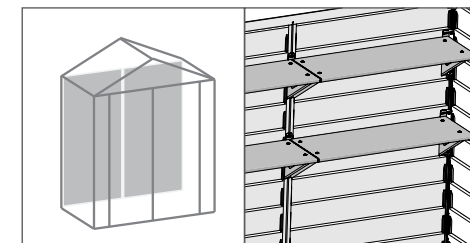

6x5 / 2x1.5 | 6x8 / 2x2.3 | 6x10 / 2x3 | 6x12 / 2x3.8

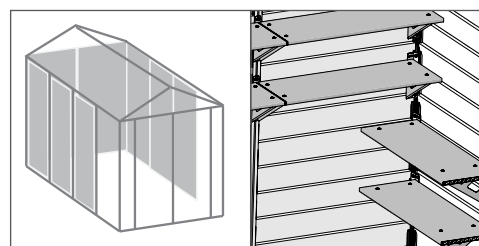

- Po wyborze preferowanej opcji należy odnaleźć odpowiednią stronę w instrukcji montażu.

PODCZAS MONTAŻU

- Panel (#9633) is not pre-drilled; therefore you must drill the holes with accordance to your chosen option.
- Metal plate (#8075) is used for mounting the shelf onto either one of the shed's corners. If you did not choose this option, there is no need to use this part; keep it for future use if needed.
- Tighten all screws when completing assembly.



- Non serrare le viti e dadi fino al completamento del processo di assemblaggio. Questi 2 icone indicano se il serraggio delle viti è necessario o meno.

UWAGA!

- Nie montuj więcej niż 2 półek na jednym panelu.

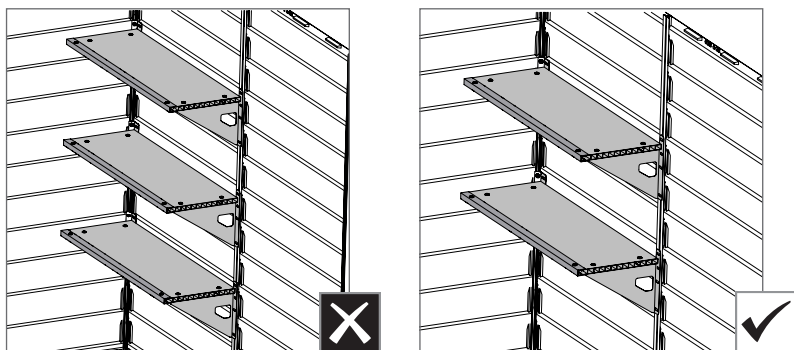

- Nie montuj więcej niż 4 półek na jednej ścianie.
- Pod żadnym względem nie montuj więcej niż 10 półek w jednym domku ogrodowym
- Pojedyncza półka może unieść do **30 kg (66 lbs)**.

4 OPCJE

Opcja #1:

Montowanie półki na środku bocznej ściany

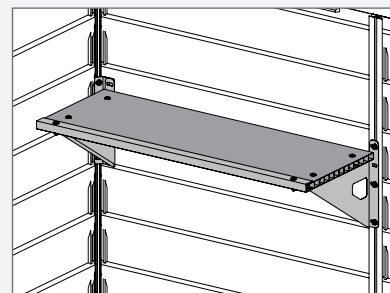

(Nie nadaje się do szopy 4x6/1.2x1.8)

Opcja #2:

Montowanie półki w rogu domku lewą stroną do wewnątrz

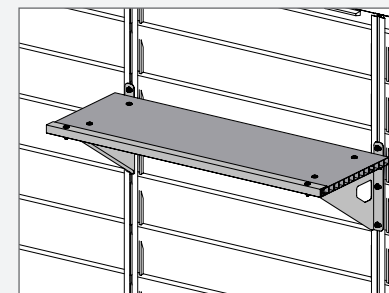

Opcja #3:

Montowanie półki w rogu domku prawą stroną do wewnątrz

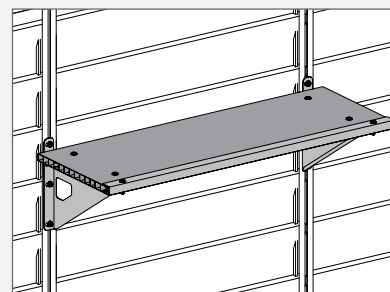

Opcja #4:

Montowanie półek obok siebie (wyłącznie na tylnej ścianie domku)

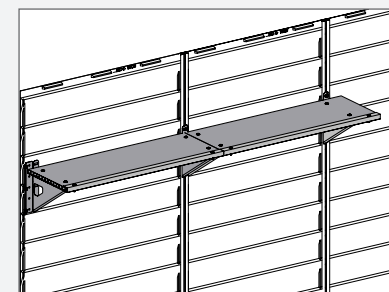

(Nie nadaje się do szopy 4x6/1.2x1.8)

SAUGOS PATARIMAS

- Saugiai išmeskite visus plastikinius maišelius. Saugokite juos vaikams nepasiekiamoje vietoje.
- Saugokite vaikus toliau nuo produkto surinkimo vietos.
- Jeigu naudojate kopėčias ar elektrinius įrankius, būtinai vadovaukitės gamintojo saugos patarimais.
- Kai kurių detalių briaunos gali būti aštrios. Naudodami komponentus būkite atsargūs.

SVARBU!

- Šie nurodymai taikomi „Palram Canopia“ Skylight™ 4x6 / 1.2x1.8 | 6x3 / 2x1 | 6x5 / 2x1.5 | 6x8 / 2x2.3 | 6x10 / 2x3 | 6x12 / 2x3.8 Rubicon™ 6x5 / 2x1.5 | 6x8 / 2x2.3 | 6x10 / 2x3 | 6x12 / 2x3.8
- Vadovaukitės instrukcijoje pateiktu žingsnių atlikimo eiliškumu.
- Šią instrukciją laikykite saugioje vietoje tolesniam naudojimui.

ĮRANKIAI IR ĮRANGA



☐ Darbo pirštinės



☐ Veržliaraktis
10 mm | 13/32"



☐ „Philips“ atsuktuvus
plokščia galvute

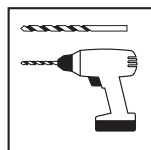

☐ Elektrinis gręžtuvas su antgaliu
7 mm | 9/32"

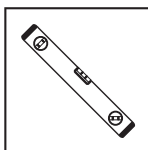

☐ Spiritinis gulsčiukas

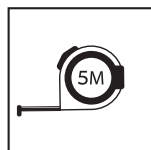

☐ Metras

PRIEŠ SURINKIMĄ

1. Prieš pradėdami šio produkto surinkimą, atidžiai perskaitykite šią instrukciją.
2. Atliekant kai kuriuos žingsnius, gali reikėti anto žmogaus pagalbos.
3. Surūšiuokite detales ir patikrinkite pagal komplektuotės detalių sąrašą.
4. Toliau pateikiama daug paveikslėlių, kuriuose aprašomos „SkyLight“ / „Rubicon“ lentynos montavimo galimybės ant visų dydžių „Palram“ „SkyLight“ / „Rubicon“ pastogių.
5. Primygtinai rekomenduojama prieš pradėdant veikti suplanuoti surinkimo darbus pagal vieną iš tolesnių parinkčių.

4x6 / 1.2x1.8

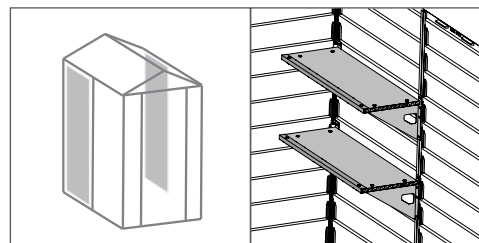

6x3 / 2x1

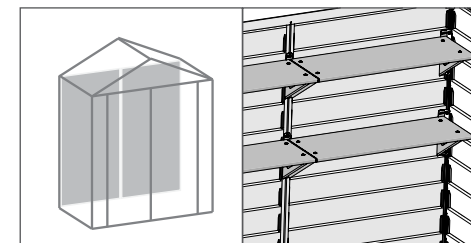

6x5 / 2x1.5 | 6x8 / 2x2.3 | 6x10 / 2x3 | 6x12 / 2x3.8

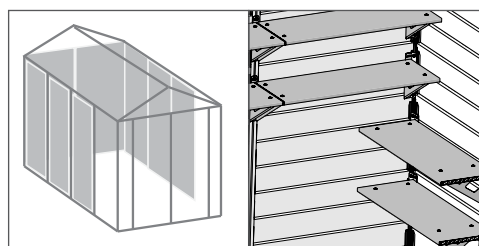

- Pasirinkę pageidaujamą parinktį, pereikite prie atitinkamo surinkimo instrukcijos puslapio.

SURINKIMO METU

- Plokštė (Nr. 9633) nėra iš anksto pragręžta, todėl privalote išgręžti angas pagal pasirinktą parinktį.
- Metalinė plokštė (Nr. 8075) naudojama montuoti lentyną ant vieno iš pastogės kampų. Jeigu nepasirinkote šios parinkties, nereikia naudoti šios detalės. Jeigu reikia, išsaugokite ją naudojimui ateityje.
- Baigę surinkimo darbus, suveržkite visus sraigtus.



- Susidūrus su šiomis piktogramomis, reikia arba šiek tiek atlaisvinti sraigtus, arba iki galo juos suveržti.

DĖMESIO!

- Nemontuokite daugiau nei 2 lentynų ant vienos plokštės.

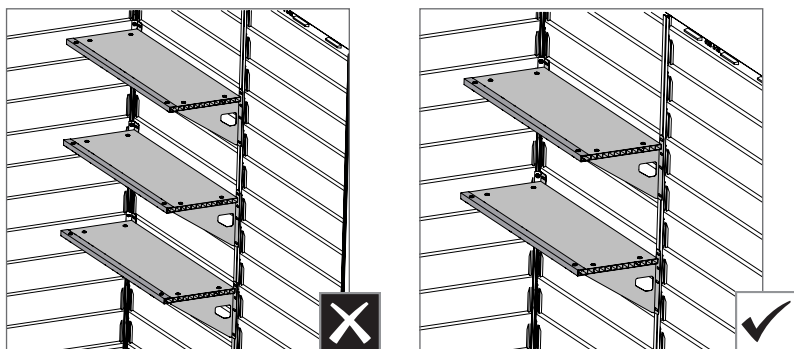

- Nemontuokite daugiau nei 4 lentynų ant vienos sienos.
- Jokiu būdu nemontuokite daugiau nei 10 lentynų vienoje pastogėje.
- Viena lentyna gali atlaikyti iki **30 kg (66 lbs)**.

4 PARINKTYS

variantas 1:

Lentynos montavimas šoninės sienos viduryje.

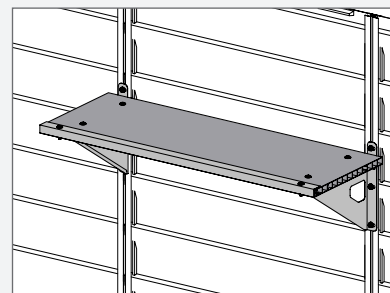

(Netinka 4x6 / 1,2x1,8 pastogei)

variantas 2:

Lentynos montavimas, kai lentynos kairė dalis susijungia su pastogės kampu.

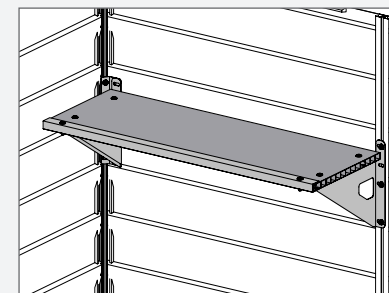
**variantas 3:**

Lentynos montavimas, kai lentynos dešinė dalis susijungia su pastogės kampu.

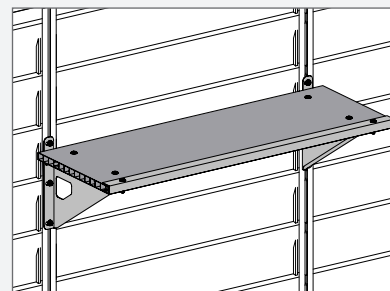



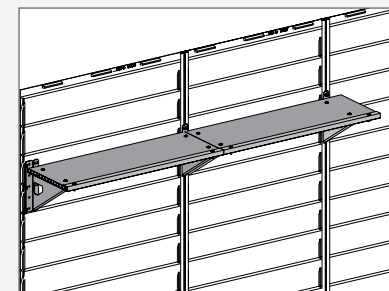

**variantas 4:**

Lentynos montavimas viena šalia kitos (tik ties pastogės galine siena)

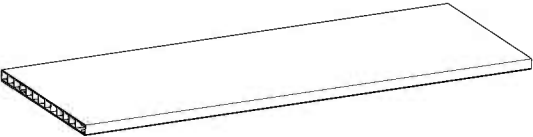
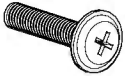
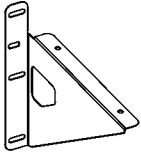

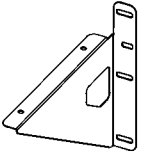
(Netinka 4x6 / 1,2x1,8 pastogei)

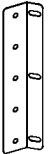
Contents

Item		Qty.	Item		Qty.
9633		1	8077		6
8074		1	466		16
8073		1	461		6
8075		1	411		4
9632		1			

OPTION #1

1

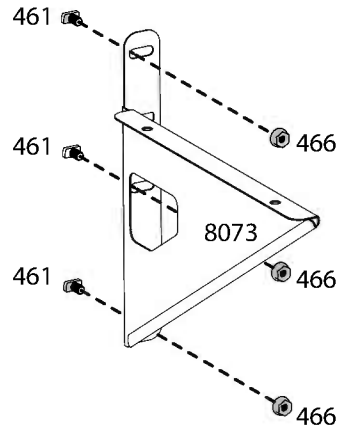
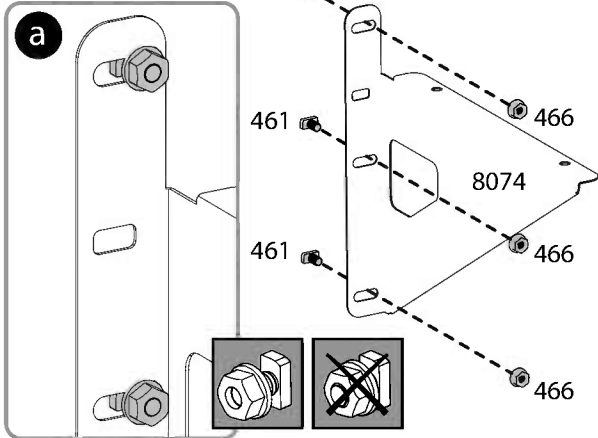
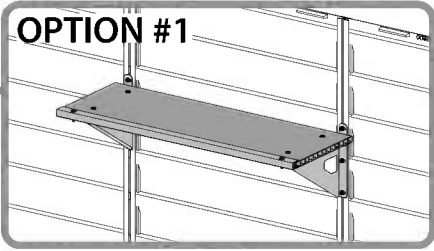

2

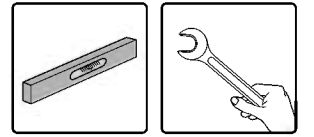
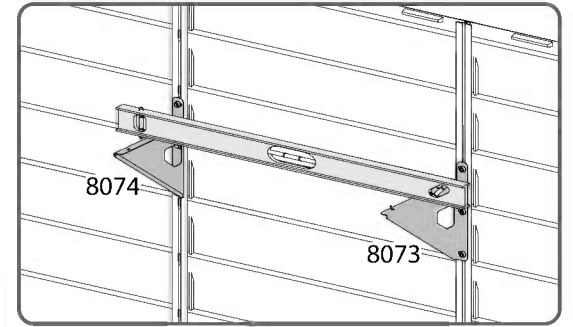
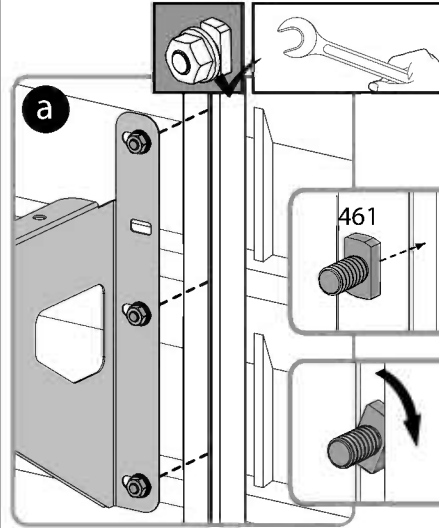

3

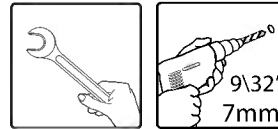
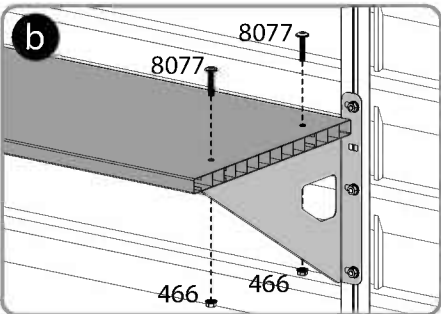
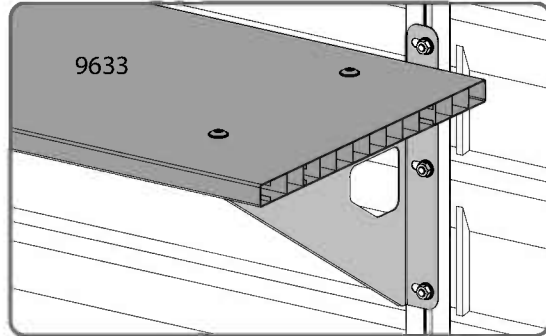
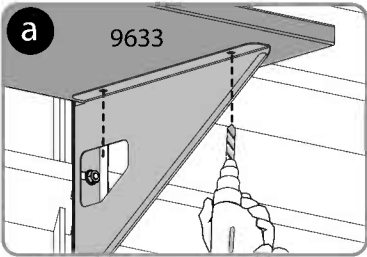

4

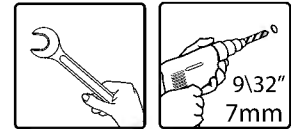
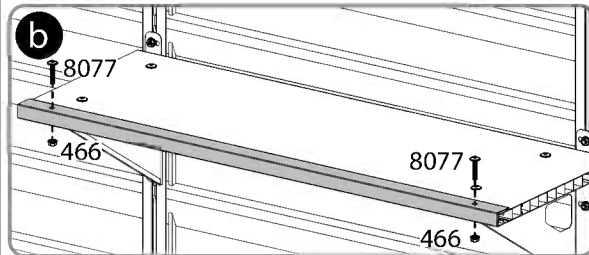
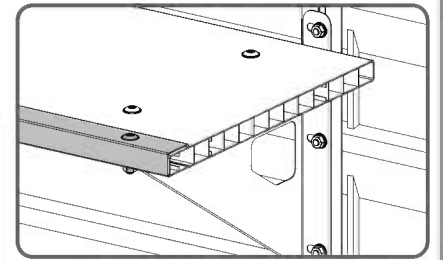
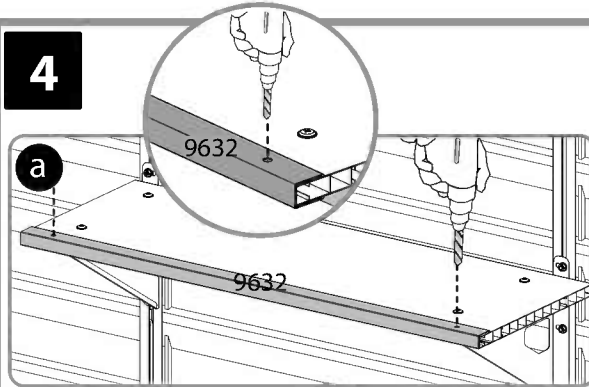

OPTION #2

1

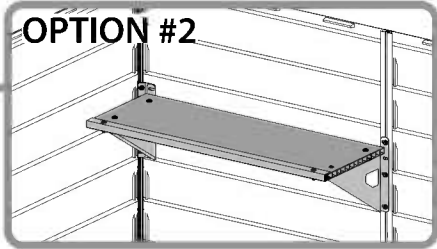

a

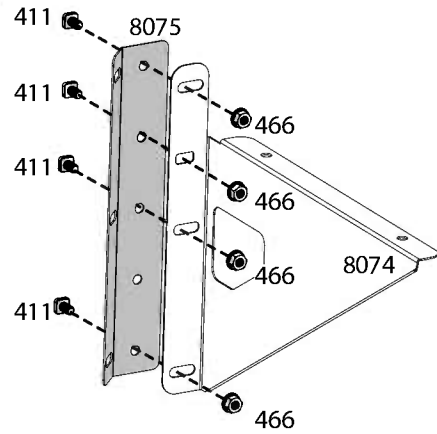
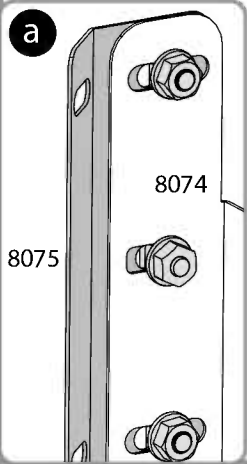

2

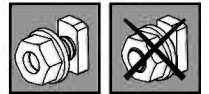
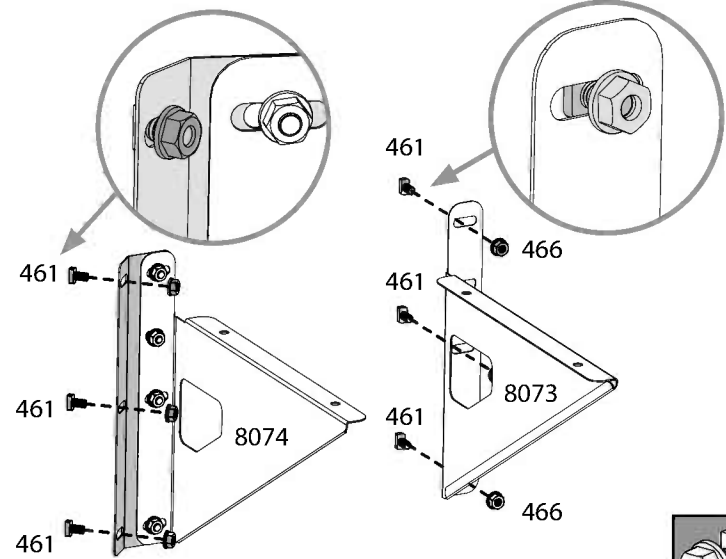

3

a

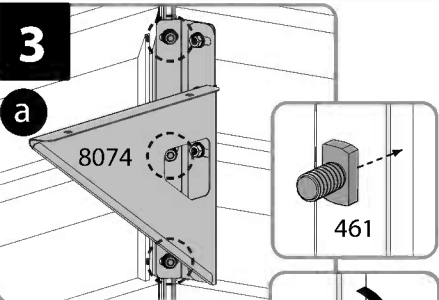

b

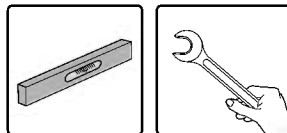
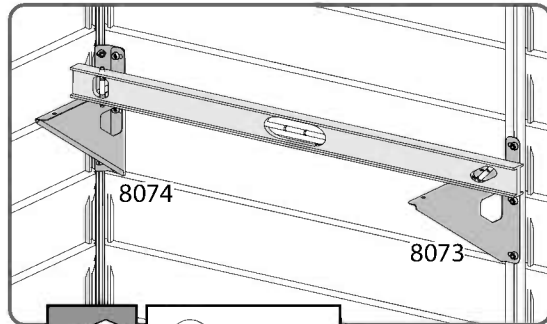
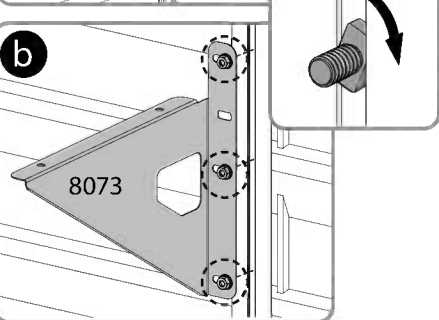

4

a

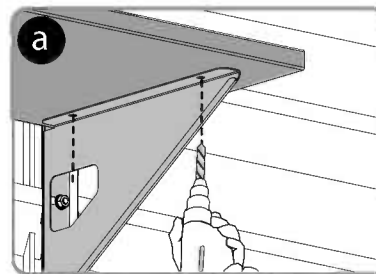

b

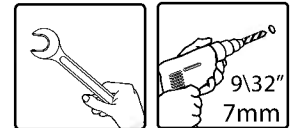
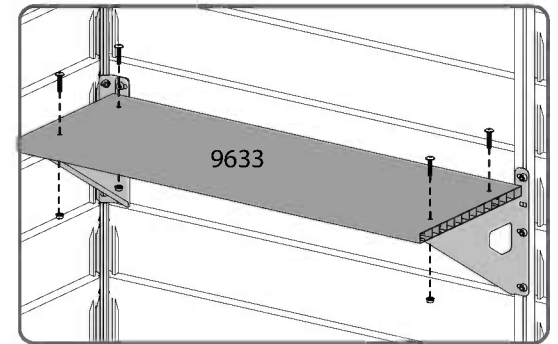
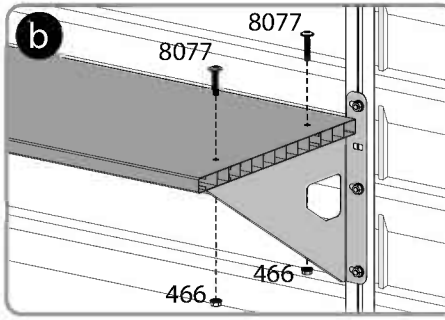

OPTION #2

5

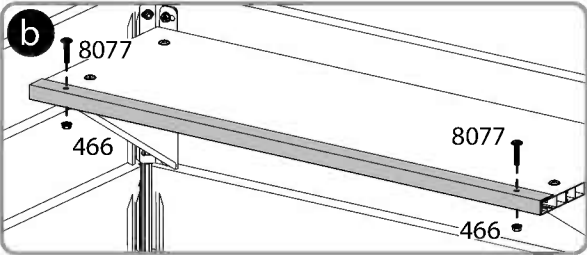
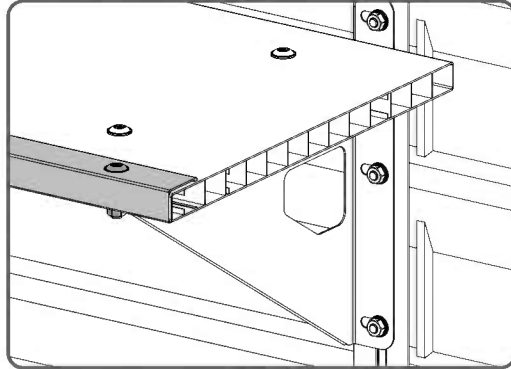
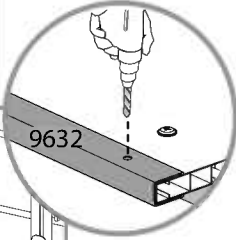
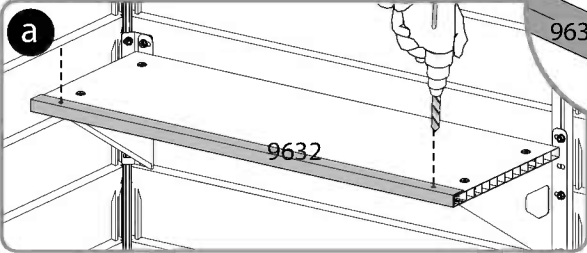
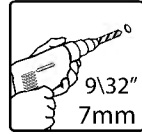
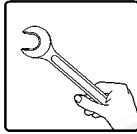
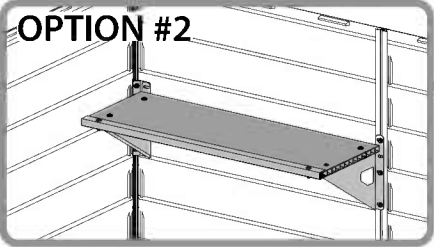

OPTION #3

1

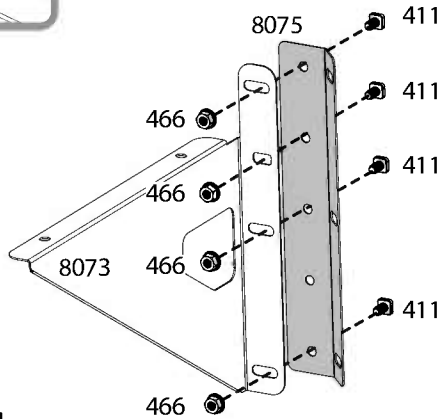
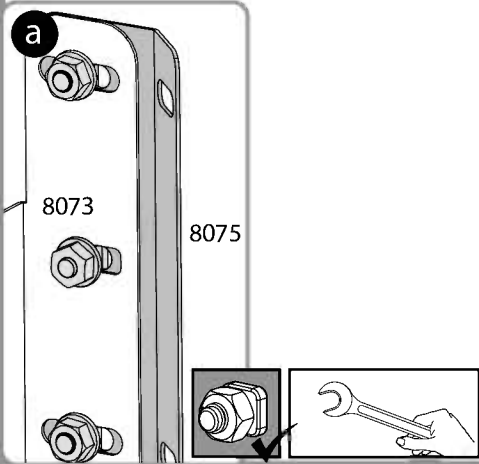
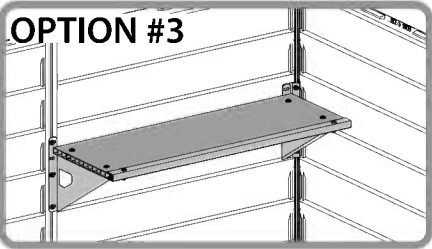

2

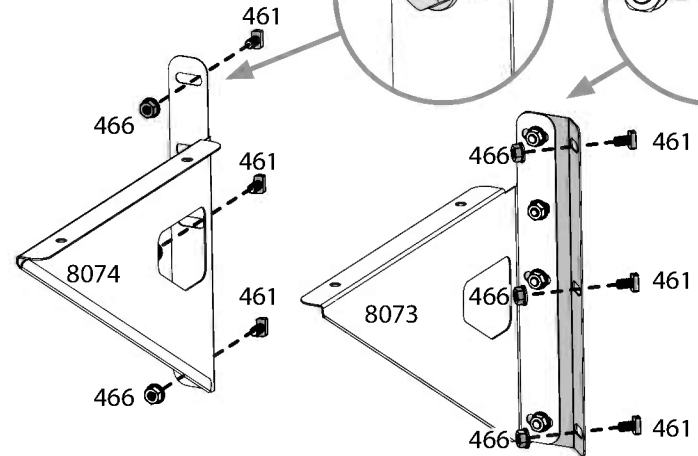
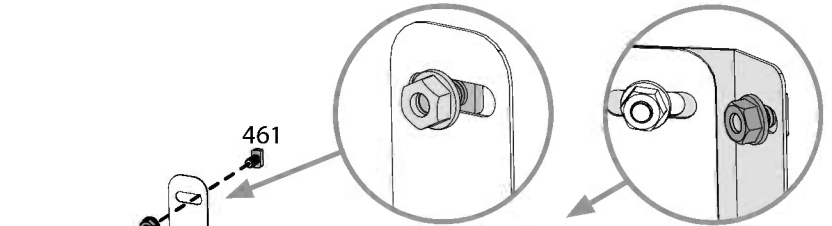

3

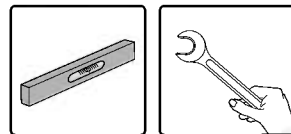
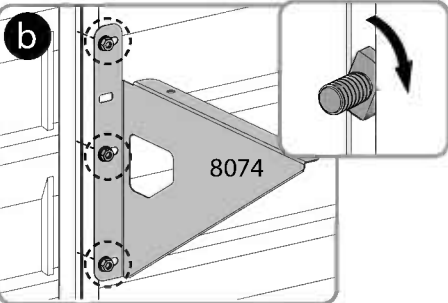
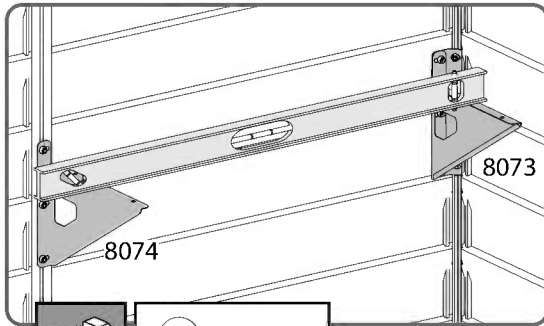
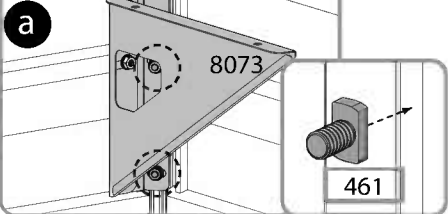

4

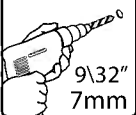
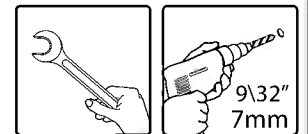
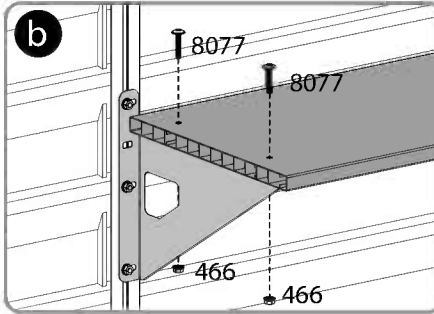
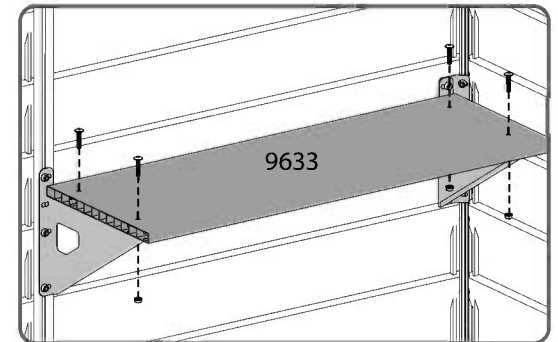
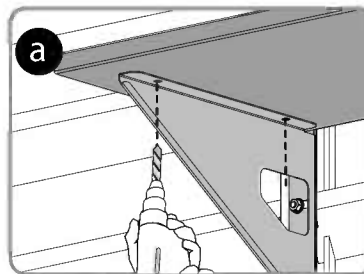

OPTION #3

5

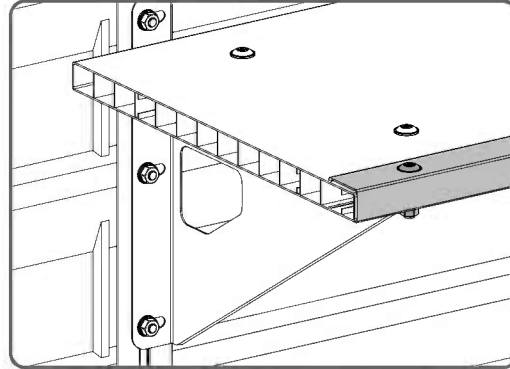
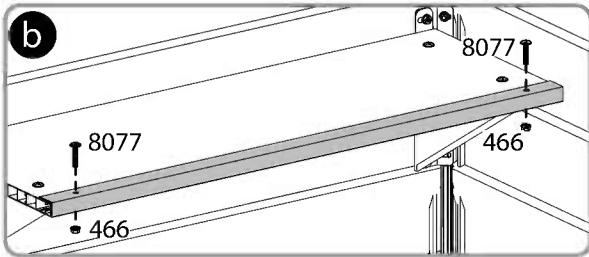
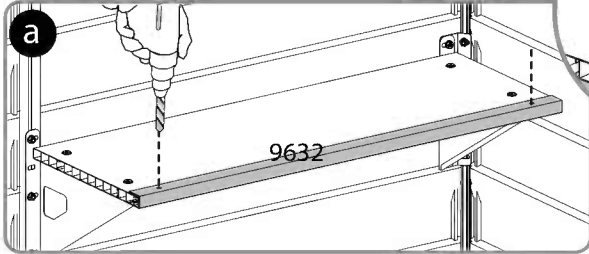
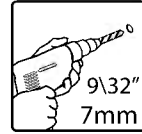
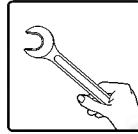
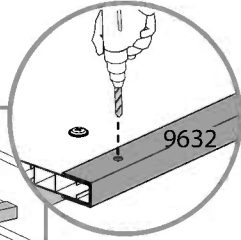
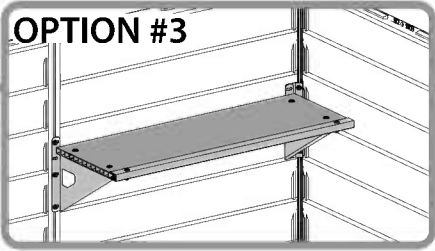

8

OPTION #4

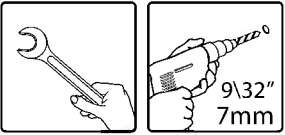
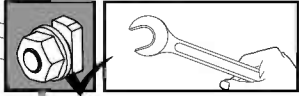
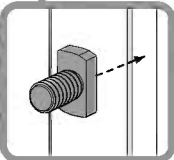
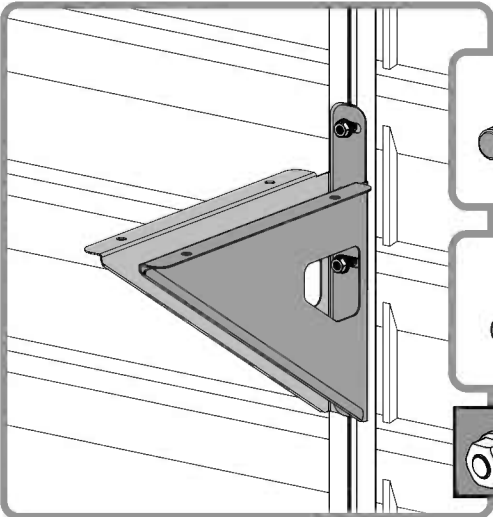
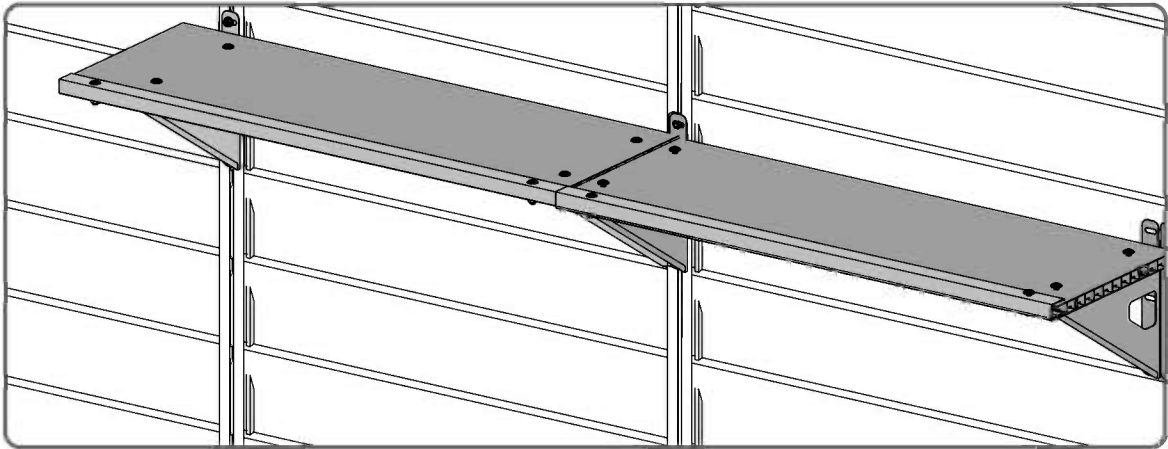
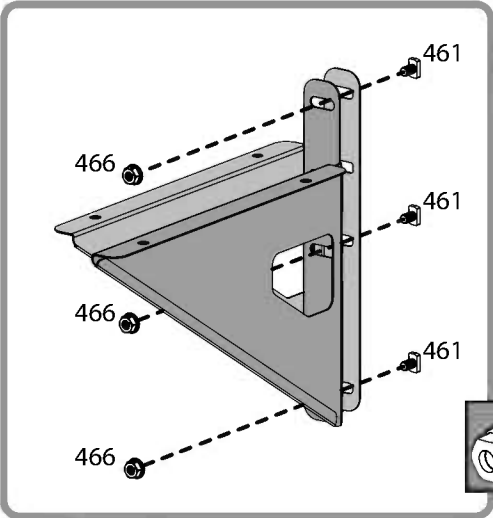
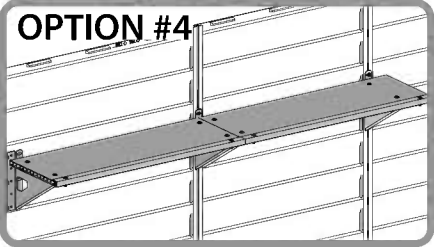

OPTION #5

1

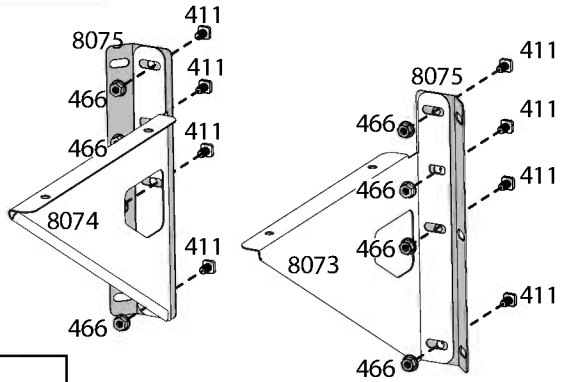
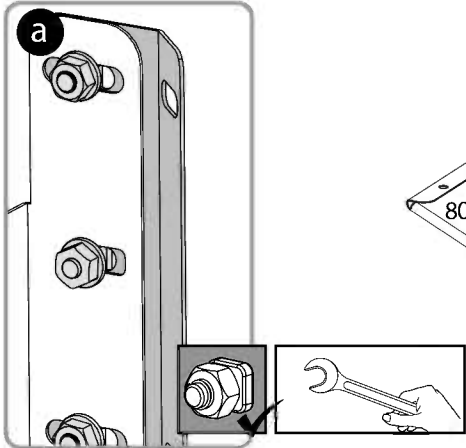
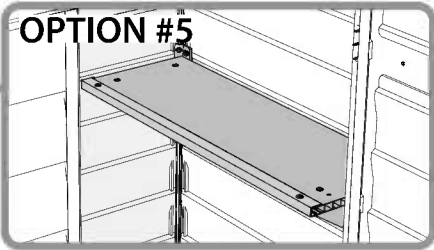

2

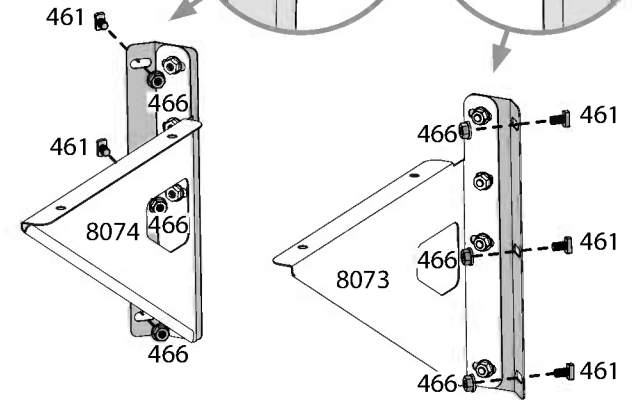
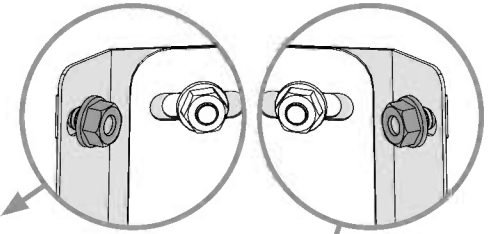

3

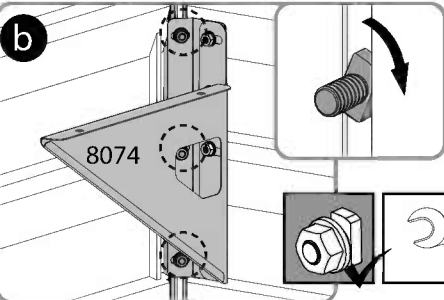
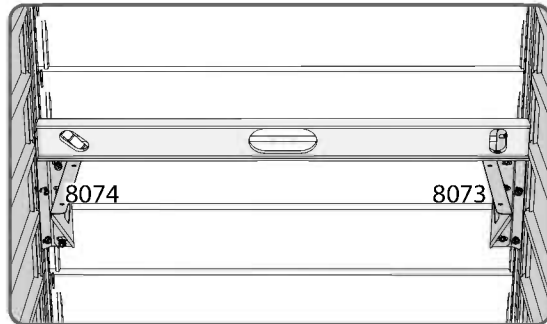
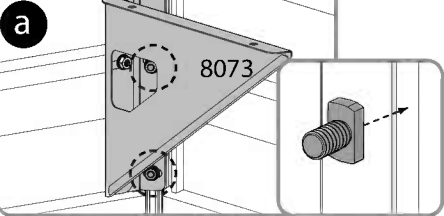

4

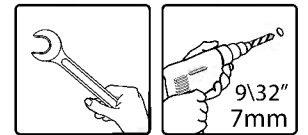
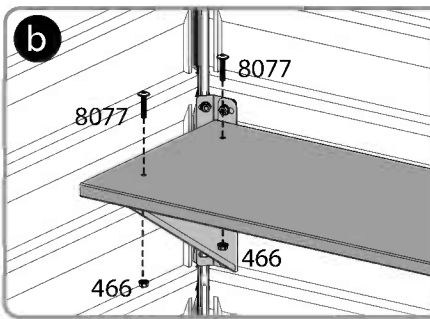
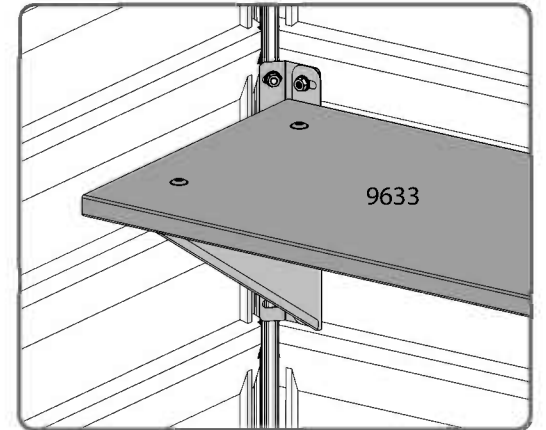
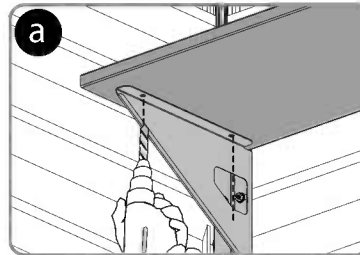

OPTION #5

5

