

# Lavavajillas de Encastre W2I HD526 A

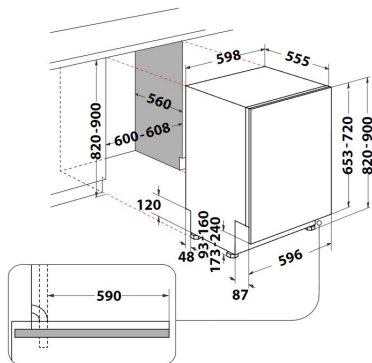

# Whirlpool

E



## 869991663290 - W2I HD526 A

- Lavavajillas de Encastre de 60cm
- Motor Inverter
- **Tecnología 6th Sense**
- Display Digital
- 14 cubiertos
- 9 programas de lavado
- **Clase energética: E**
- Indicadores de recarga de sal y abrillantador
- Bandeja superior de altura ajustable
- Duración del ciclo ECO (min.): 215
- **Programas:** Eco, Intensivo, 6th Sense, Lavado y Secado Rápido, Rápido 28', Silencioso, Desinfección, Prelavado, Autolimpieza
- **Opciones:** Media Carga, Inicio Diferido, Pastillas
- Protección antifugas: **Aquastop**
- Nivel de ruido: 46 dB(A) - Clase C
- Consumo de agua: 9.5 L/Ciclo
- Consumo de energía: 95 kWh/100 ciclos
- 5 años de garantía en el motor

EAN 8003437643101

**MEDIDAS** 820-900 x 598 x 555 mm (AlxAnxF)