



CABEZAL TERMOSTÁTICO INTELIGENTE
Smart radiator thermostat
Cabeça termostática inteligente

REF. 401307G - 401371G



ES ÍNDICE

Componentes	1
Características	2
Servicio técnico.....	3
¿Qué necesitas?	4
¿Cómo funciona?	5
Instalación cabezal	6
Adaptadores	7
Bridge.....	13
Sincronización bridge con la app	15
Iconos app	17
Sincronización cabezal	18
Programación app....	19
Funciones	20
Iconos del cabezal	23
Sincronización por voz	24
Otras configuraciones	25
Declaración CE.....	xx

EN INDEX

Components	27
Features	28
Technical service	29
What do you need?	30
How does it work? ...	31
Head installation.....	32
Adapters	33
Bridge	39
Bridge synchronization with app	41
App Icons	43
Head synchronization	44
App programming ...	45
Function setting	46
Head Icons	49
Voice synchronization	50
Other configurations	51
EC Declaration	xx

PT ÍNDICE

Componentes	53
Características	54
Serviço técnico	55
O que você precisa?	56
Como funciona?	57
Instalação cabeça ...	58
Adaptadores	59
Bridge.....	65
Sincronização Bridge com app	67
Ícones de app	69
Sincronização do fuso	70
Programação app	71
Funções	72
Ícones de cabeça	75
Sincronização de voz	76
Otras configurações	77
Declaração CE	xx

Cabezal

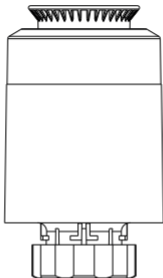

Adaptadores

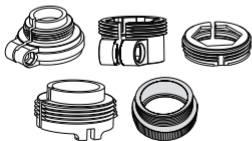

Émbolos

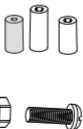

Pilas 2xAA



Tuerca y tornillo

ES CABEZAL TERMOSTÁTICO INTELIGENTE

Características:

- Alimentación: pilas 2AA (No uses pilas recargables)
- Tiempo medio de duración de las pilas: 1 año
- Rango de precisión: 0.5°C
- Rango de medición de temperatura: 0°C ~ 50°C
- Rango de operación de temperatura: 5°C ~ 30°C
- Temperatura de transporte y conservación: -10°C ~ 60°C
- Rango de transmisión de señal Zigbee: 30 metros
- Pantalla: Led
- IP: 21
- Conexión: M30x1.5mm
- Potencia máxima transmitida <20dBm

Si tienes alguna consulta o problema, recuerda que puedes contactar con nosotros a través de **customer@garza.es**. También podrás encontrar recursos de utilidad en nuestro canal de YouTube y en nuestra **Base de Conocimientos en customer.garza.es**.



Canales
de asistencia



Base de
conocimientos



YouTube

@GarzaSpain

DESCARGA APP

Desde aquí podrás descargar la app de garza, necesaria para poder usar el cabezal correctamente.



¿ QUÉ NECESITAS PARA SU INSTALACIÓN ?

4

Un radiador con válvula termostática automática (No sirven las válvulas manuales).

Un adaptador de rosca para instalar la válvula con el cabezal. Los adaptadores más comunes vienen incluidos, pero si tu radiador no fuera compatible con ninguna rosca contáctanos en customer@garza.es

Un Bridge a zigbee para sincronizar el cabezal con el router. Recomendamos el uso del Bridge Zigbee de Garza (se incluye en el Starter Kit), pero hay otros compatibles.

Dos pilas AA para alimentar el cabezal (incluidas).

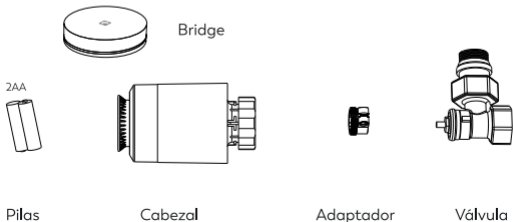

Con el Bridge conectado a tu router se crea una red de radio (Zigbee) que permite controlar de forma remota la válvula termostática de tu radiador. Puedes conectar tantas válvulas como desees y accionarlas desde la App Garza Smart o mediante tu asistente de voz (Alexa, Google).

Detecta la temperatura ambiente de cada habitación y, en función de la temperatura seleccionada, el mecanismo abrirá o cerrará el paso del agua al radiador, podrás ahorrar hasta un 25% del gasto en calefacción.

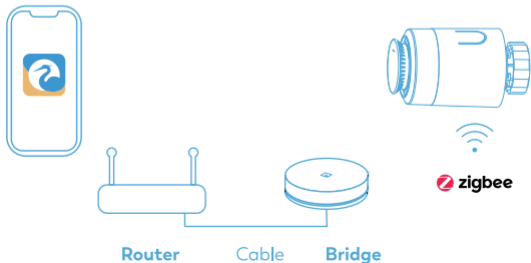

1

Presiona en la hendidura para extraer el compartimento de las pilas e introdúcelas

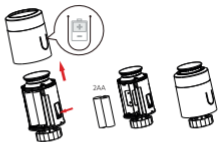

2

Enrosca el cabezal con la válvula mediante el adaptador

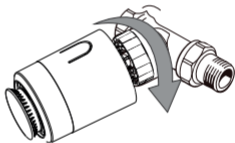

3

Presiona el botón giratorio brevemente. Verás en la pantalla parpadear la palabra "LA". El dispositivo se quedará configurado con las opciones por defecto

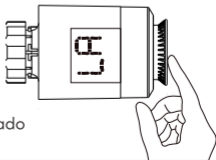

Danfoss



DANFOSS RAV

Válvula de 3/4 + émbolo largo.

Danfoss

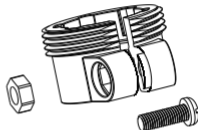

DANFOSS RA

Válvula de 1/2.

CALEFFI
Hydronic Solutions



CALEFFI

Válvula de 1/2.

GIACOMINI
WATER E-MOTION

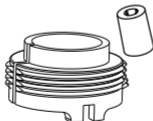

GIACOMINI

Válvula de 1/2 + émbolo corto.

ORKLI

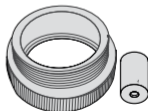

ORKLI

Válvula de metal de 1/2 + émbolo fino metal.

DANFOSS RAV

Válvula de 3/4 + émbolo largo.

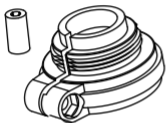

La válvula Danfoss 3/4 necesita instalar un émbolo largo en la parte inferior del controlador. Los accesorios deben colocarse directamente en la válvula.

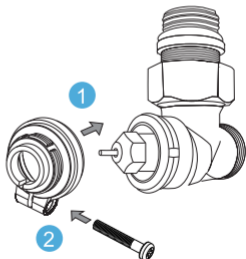
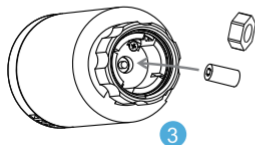

The Danfoss logo, featuring the brand name in a stylized, cursive script.

DANFOSS RA

Válvula de 1/2.

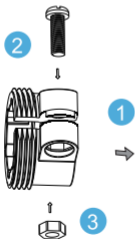
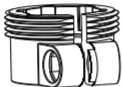

Apriete los tornillos después de fijar el conector de la válvula.

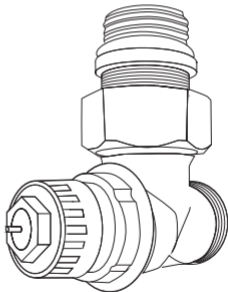

CALEFFI

Válvula de 1/2.

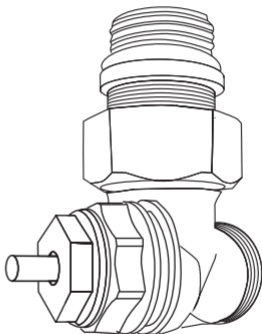
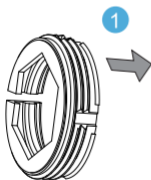

GIACOMINI

Válvula de 1/2
+ émbolo corto.

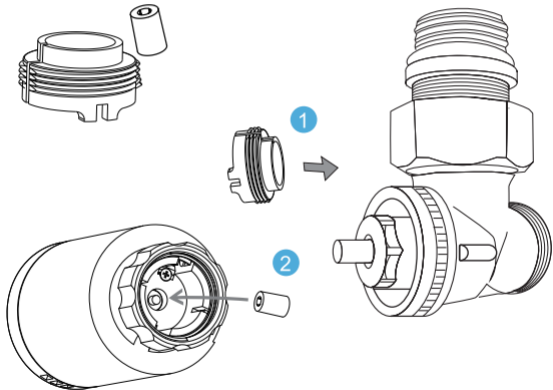

ORKLI

Válvula de metal de 1/2 + émbolo fino metal.

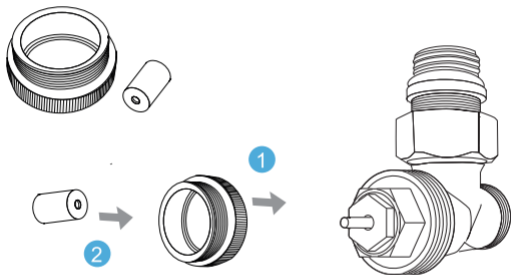

En caso de tener una válvula manual, debes adquirir una válvula termostática con un acople del tipo M30 x 1.5 mm. Si ya tienes una válvula termostática comprueba su compatibilidad desde este QR.

INSTALACIÓN DEL BRIDGE GARZA (INCLUIDO EN STARTER KIT)

La instalación del bridge es necesaria para sincronizar el cabezal termostático con la app de Garza.

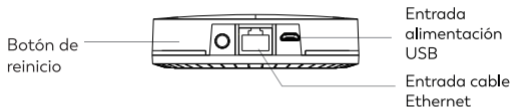

INSTALACIÓN DEL BRIDGE GARZA (INCLUIDO EN STARTER KIT)

14

Cuando la luz roja deje de parpadear significará que el bridge esta correctamente emparejado.

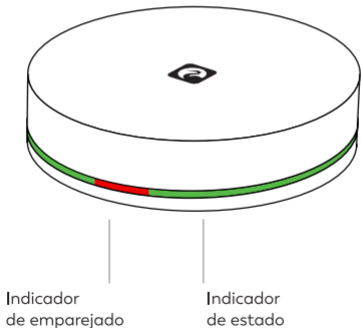

5

Elige tu red wifi de 2,4 GHz e introduce la contraseña de esta. La contraseña de tu red wifi puede estar en la parte trasera del router.



6

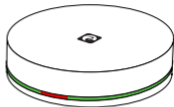

La luz verde en el dispositivo Bridge indicará que se ha sincronizado.

¿NECESITAS MÁS INFORMACION?

Consulta este QR si necesitas información más detallada de como conectar el bridge con tu app.





BOTONES APP

1. Historial.
2. Temperatura de la estancia.
3. Subir la temperatura.
4. Temperatura deseada.
5. Bajar la temperatura.
6. Deslizar para apagar y encender.
7. Recordatorio de uso de programación.
8. Modo salir: Pone el termostato a 16°, al desactivarlo. Volverá al estado anterior.
9. Programaciones.
10. Ajustes.

1

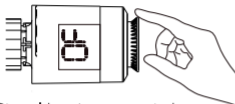

Gira el botón rotatorio hasta que aparezca **“OF”**

2

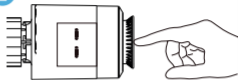

Pulsa el botón rotatorio de tu cabezal hasta que en la pantalla salga **“--”**

3



En el menú de la App Garza asegúrate de estar en el apartado **“Mi casa”**.
Entra en tu Bridge.

4



En tu móvil, desde el menú del Bridge, pulsa en **“Agregar Dispositivos”** y después en **“Led Ya Parpadea”** o **“Continuar”**.

5



Espera unos seg. En la pantalla del cabezal aparecerá **“PA”**. Esto indica que la sincronización es correcta.

Entra en la app y selecciona tu válvula.

Selecciona **“Programa”**.

Tras acceder, verás el menú de programación, donde debes seleccionar los días de la semana que quieres tener habilitada la programación.

Una vez realizado esto, deberás establecer día a día los tramos horarios a configurar .

El icono del sol, ☀️, será el primer arranque del día, el de la luna el último 🌙.

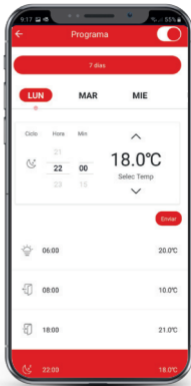

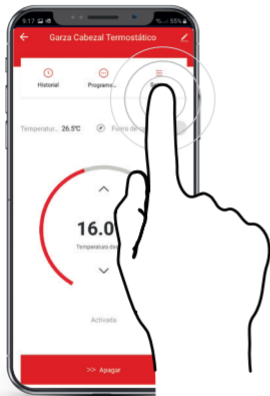

Setting



Protección de la válvula



Anticongelación



Detección de ventana abierta



Protección infantil



Calibración de temperatura



Enlazar dispositivos

PROTECCIÓN DE LA VÁLVULA

Si el radiador está sin funcionar durante dos semanas o más puede dañarse o atascarse por óxido o cal. Por ello el cabezal abrirá la válvula y la hará funcionar por 20 segundos cada dos semanas. La pantalla mostrará **"A5"**.

FUNCIÓN ANTI-CONGELACIÓN

Esta función abre la válvula cuando la temperatura baja de 5°C. Cuando la temperatura sube hasta los 8°C, la válvula se vuelve a cerrar.

FUNCIÓN DE VENTANA ABIERTA

Si la ventana está abierta y la temperatura cae bruscamente 6°C en un periodo de 4 minutos el cabezal cerrará la válvula y mostrará **"OP"** en su pantalla. Si se cierra la ventana y la temperatura de la habitación se incrementa en 2°C, el cabezal volverá a operar.

FUNCIÓN DE PROTECCION INFANTIL

Si se presiona el botón rotatorio durante unos segundos se activará la opción de bloqueo para niños, mostrando en la pantalla **"LC"**. Si se vuelve a presionar el botón unos 10 segundos volverá a estar desbloqueado.

CALIBRACIÓN DE TEMPERATURA

Es posible que necesitemos ajustar un diferencial de temperatura para compensar la temperatura que nos muestra el cabezal respecto a la temperatura “real” (por ejemplo, la que nos muestra un termómetro que queremos tomar como referencia).

ALARMA

Durante su funcionamiento normal.

Si el sensor NTC sufre daños, se mostrará “ER”.

AVISO DE BATERÍA BAJA

Cuando la pila del cabezal se esté agotando mostrará un icono de batería baja.

SOBREESCRIBIR TEMPORALMENTE

Durante una programación pre-establecida, si se quiere modificar la temperatura de forma manual, se puede girar el botón rotatorio. La nueva configuración manual permanecerá hasta el fin del periodo de la programación.

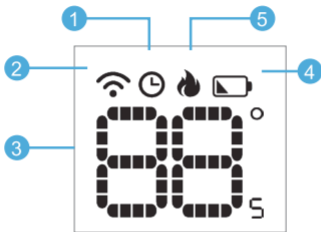

Modo programación.

Conectado.

Indicador de temperatura.

Batería baja.

Funcionamiento.

Desde la App de Alexa | OK Google podrás buscar la Skill Garza Smart. Después de instalarla deberás introducir tus datos de log-in de la aplicación Garza.

Para controlar por voz este dispositivo puedes seguir las indicaciones que encontrarás en los QRs.



Configurar con Alexa



Configurar con Google

¿CÓMO ENLAZAR LAS VÁLVULAS TERMOSTÁTICAS ENTRE SI?

La principal ventaja de los cabezales o válvulas termostáticos es poder controlar la temperatura de cada radiador de tu hogar, pero si quieres combinar varios cabezales que controlen una zona más amplia puedes hacerlo, para ello sigue los pasos que te indicamos en este QR.



EL DISPLAY DE MI VÁLVULA TERMOSTÁTICA ESTÁ AL REVÉS

¿Las letras de tu válvula termostática están invertidas y no puedes verlas adecuadamente?. Averigua como solucionarlo, para ello sigue los pasos que te indicamos en este QR.





SMART RADIATOR THERMOSTAT

REF. 401307G - 401371G

TRV

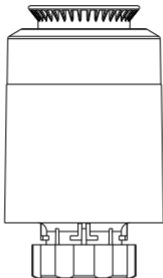

Adapter

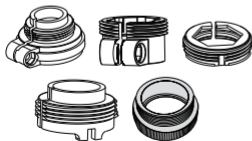

Plunger



Batteries 2xAA



Nut and bolt



EN SMART THERMOSTAT RADIATOR

Characteristics:

- Power: 2AA batteries (Do not use rechargeable batteries)
- Average battery life: 1 year
- Accuracy range: 0.5°C
- Temperature measurement range: 0°C ~ 50°C
- Operating temperature range: 5°C ~ 30°C
- Transportation and storage temperature: -10°C ~ 60°C
- Zigbee signal transmission range: 30 meters
- Led screen
- IP: 21
- Connection: M30x1.5mm
- Maximum transmitted power <20dBm

If you have any questions or problems, remember that you can contact us at **customer@garza.es**.

You can also find useful resources on our YouTube channel and in our **Knowledge Base** at **customer.garza.es**.



Channels
of assistance



Base of
knowledge



@GarzaSpain

DOWNLOAD APP

From here you can download the garza app, necessary to be able to use the head correctly.



- A radiator with an automatic thermostatic valve (the manual valves do not work).
- A threaded adapter to install the valve with the head. The most common adapters are included, but if your radiator is not compatible with any thread, contact us at customer@garza.es
- A Zigbee Bridge to synchronize the head with the router. We recommend the use of Garza's Zigbee Bridge (included in the Starter Kit), but there are other compatible ones.
- Two AA batteries to power the head (included).



Bridge

2AA



Batteries



Thermostatic head



Adapter



Valve

HOW DOES IT WORK?

With the Bridge connected to your router, a radio network (Zigbee) is created that allows you to remotely control the thermostatic valve of your radiator. You can connect as many valves as you want and activate them from the Garza Smart App or through your voice assistant (Alexa, Google).

It detects the ambient temperature in each room and, depending on the selected temperature, the mechanism will open or close the flow of water to the radiator, thus saving up to 25% of heating costs

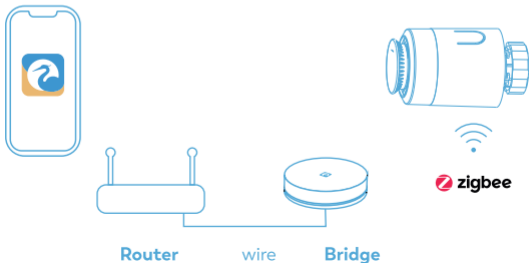

1

Press on the indentation to remove the battery compartment and insert the batteries

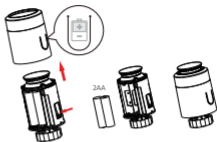

2

Screw the head with the valve using the adapter



3

Press the rotary button briefly. You will see on the screen flashing the word "LA". The device will remain configured with the default options

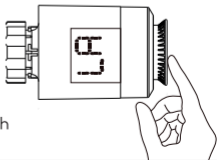

Danfoss



DANFOSS RAV

3/4 valve + long plunger.

Danfoss

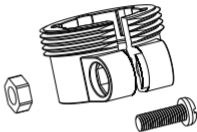

DANFOSS RA

1/2 valve.

CALEFFI
Hydronic Solutions



CALEFFI

1/2 valve.

GIACOMINI
WATER E-MOTION

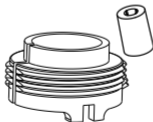

GIACOMINI

1/2 valve +
short plunger.

ORKLI

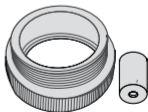

ORKLI

1/2 metal valve +
thin metal plunger.

DANFOSS RAV

3/4 valve + long plunger.

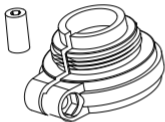

Danfoss 3/4 valve needs to install a long plunger at the bottom of the controller. Accessories must be placed directly on the valve.

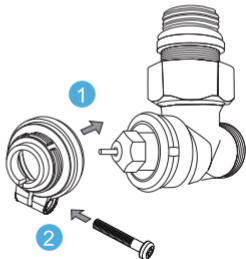
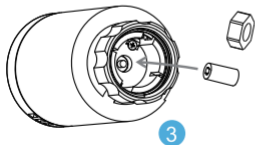

DANFOSS RA

1/2 valve.



Tighten the screws after fixing the valve connector.

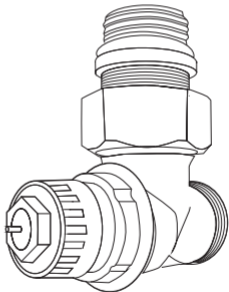

ADAPTERS

36

CALEFFI

1/2 valve.

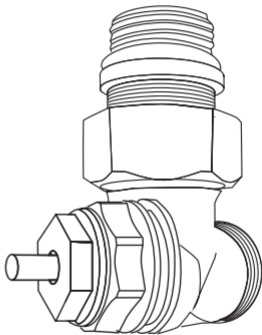
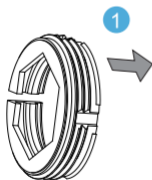

GIACOMINI

1/2 valve +
short plunger.

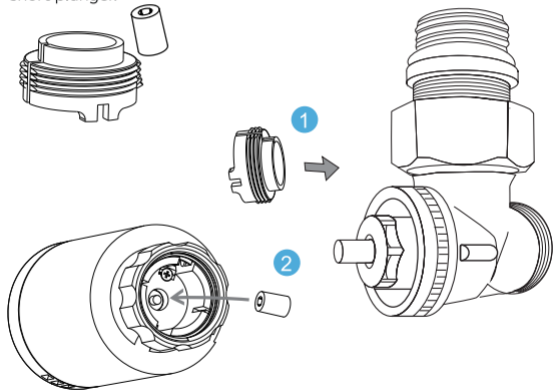

ORKLI

1/2 metal valve + thin metal plunger.

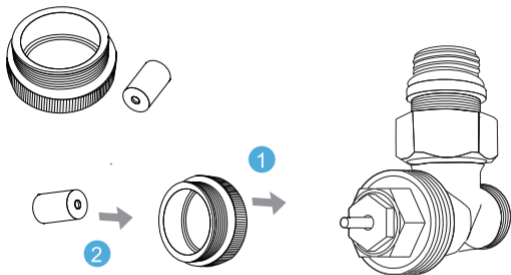

If you have a manual valve, you must purchase a thermostatic valve with a coupling of the type M30 x 1.5 mm. If you already have a thermostatic valve check its compatibility from this QR.

INSTALLING THE BRIDGE GARZA (INCLUDED IN STARTER KIT)

The installation of the bridge is necessary to synchronize the thermostatic head with the Garza app.

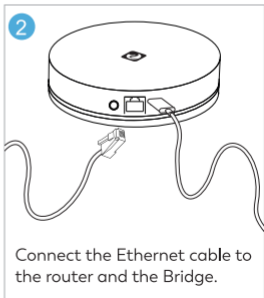
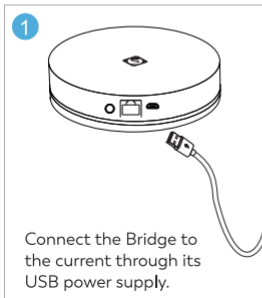
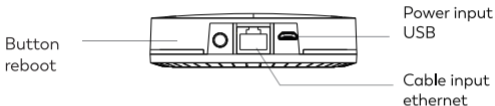

INSTALLING THE BRIDGE GARZA (INCLUDED IN STARTER KIT)

40

When the red light stops flashing, it means that the bridge is correctly paired.

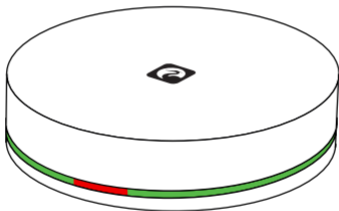

Indicator
of paired

Indicator
of state

1

Create a family (it will only be necessary to create it once) to manage all the devices, for this access the **"profile" icon**  located in the lower right corner of the app.



2

Select **"family management"** and **"add family"**. Fill in the data and save the family.

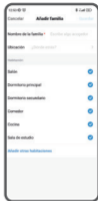

3

Go back to the app's main menu, and make sure you have the family you just created selected in the top left. Select **"add device"**.



4

You will see a menu with Garza devices. Select **"Bridge"**.



5

Choose your 2.4 GHz Wi-Fi network and enter the password for it. The password for your Wi-Fi network can be on the back of the router.



6

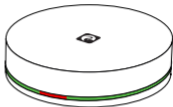

The green light on the Bridge device will indicate that it has been paired.

YOU NEED MORE INFORMATION?

Consult this QR if you need more detailed information on how to connect the bridge with your app.





APP BUTTONS

Record.

Room temperature.

Turn up the temperature.

Desired temperature.

Lower the temperature.

Slide to turn on and off.

Schedule usage reminder.

Exit mode: Sets the thermostat to 16°, when deactivated. It will return to the previous state.

Schedules.

Settings.

1

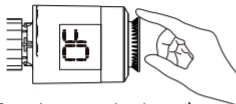

Turn the rotary knob until **OF** appears

2

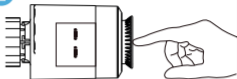

Press the rotary button on your head until the display shows **--**

3



In the menu of the Garza App, make sure you are in the **"My house"** section. Enter your Bridge.

4



On your mobile, from the Bridge menu, Click on **"Add Devices"** and then on **"Led Already Flashes" or "Continue"**.

5

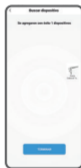

Wait a few sec. **"PA"** will appear on the head display. This indicates that the synchronization is correct.

Enter the app and select your valve.

Select **“Program”**.

After accessing, you will see the programming menu, where you must select the days of the week that you want to have the programming enabled.

Once this is done, you must establish the time slots to be configured day by day.

The sun icon ☀️ will be the first start of the day, the moon 🌙 the last. 🔄

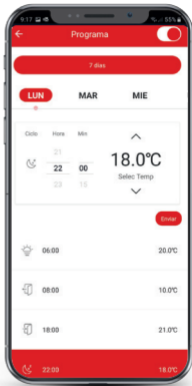

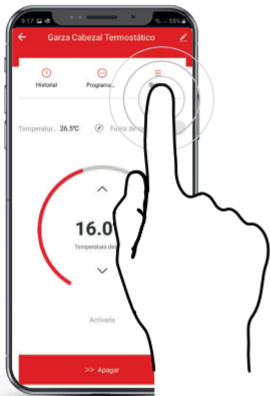

Setting



Protection of the valve



Antifreeze



Detection of open window



Child protection



Temperature calibration



Link devices

VALVE PROTECTION

If the radiator is not working for two weeks or more, it can be damaged or clogged by rust or limescale. Therefore the head will open the valve and make it work for 20 seconds every two weeks. The display will show **"A5"**.

ANTI-FREEZE FUNCTION

This function opens the valve when the temperature drops below 5°C. When the temperature rises to 8°C, the valve closes again.

OPEN WINDOW FUNCTION

If the window is open and the temperature drops sharply 6°C in a period of 4 minutes, the head will close the valve and show **"OP"** on its screen. If the window is closed and the room temperature increases by 2°C, the head will resume operation.

CHILD PROTECTION FUNCTION

If the rotary button is pressed for a few seconds, the child lock option will be activated, showing **"LC"** on the screen. If the button is pressed again for about 10 seconds it will be unlocked again.

TEMPERATURE CALIBRATION

It is possible that we need to adjust a temperature differential to compensate the temperature that the head shows us with respect to the “real” temperature (for example, the one that shows us a thermometer that we want to take as reference).

ALARM

During its normal operation.

If the NTC sensor is damaged, it will display “**ER**”.

LOW BATTERY NOTICE

When the head battery is running low it will display a low battery icon.

TEMPORARILY OVERWRITE

During a pre-established programming, if you want to modify the temperature manually, you can turn the rotary knob. The new manual configuration will remain until the end of the programming period.

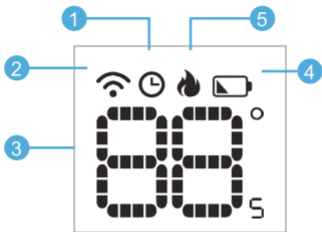

Programming mode.

Connected.

Temperature indicator.

Low battery.

Functioning.

From the Alexa App | OK Google you can search for the Skill Garza Smart. After installing it, you must enter your Garza application log-in data.

To control this device by voice you can follow the indications that you will find in the QRs.



Set up with Alexa



Set up with Google

HOW TO LINK THE THERMOSTATIC VALVES TOGETHER?

The main advantage of thermostatic heads or valves is to be able to control the temperature of each radiator in your home, but if you want to combine several heads that control a larger area, you can do so, follow the steps indicated in this QR.



THE DISPLAY OF MY THERMOSTATIC VALVE IS BACKWARDS

Are the letters on your thermostatic valve reversed and you can't see them properly? Find out how to solve it, to do so follow the steps that we indicate in this QR.





CABEÇA TERMOSTÁTICA INTELIGENTE

REF. 401307G - 401371G

Cabeça

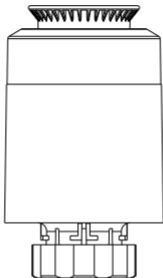

Adaptadores

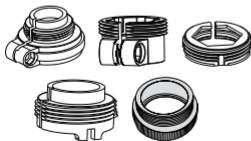

Êmbolos



Baterias 2xAA



Porca e parafuso



PT CABEÇA TERMOSTÁTICA INTELIGENTE

Características:

- Alimentação: 2 pilhas AA (não use pilhas recarregáveis)
- Duração média da bateria: 1 ano
- Faixa de precisão: 0,5°C
- Faixa de medição de temperatura: 0°C ~ 50°C
- Faixa de temperatura operacional: 5°C ~ 30°C
- Temperatura de transporte e armazenamento: -10°C ~ 60°C
- Faixa de transmissão do sinal Zigbee: 30 metros
- Tela de led
- PI: 21
- Conexão: M30x1.5mm
- Potência máxima transmitida <20dBm

Se você tiver alguma dúvida ou problema, lembre-se de que pode nos contatar em **customer@garza.es**.

Você também pode encontrar recursos úteis em nosso canal do YouTube e em nossa **Base de Conhecimento em customer.garza.es**



Canais
de asistencia



Base de
conocimientos



 YouTube
@GarzaSpain

BAIXAR APP

A partir daqui você pode baixar o aplicativo garza, necessário para poder usar o cabeçote corretamente.



 Garza
Smart

GET IT ON
Google Play

Available on the
App Store

Um radiador com válvula termostática automática (as válvulas manuais não funcionam).

Um adaptador roscado para instalar a válvula com a cabeça. Os adaptadores mais comuns estão incluídos, mas se o seu radiador não for compatível com nenhuma rosca, entre em contato conosco em customer@garza.es

Uma ponte Zigbee para sincronizar a cabeça com o roteador. Recomendamos o uso do Zigbee Bridge da Garza (incluso no Starter Kit), mas existem outros compatíveis.

Dois pilhas AA para alimentar a cabeça (incluídas).

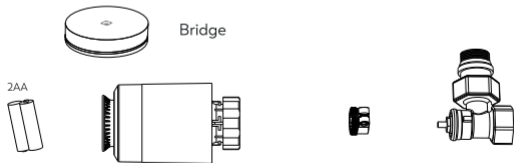

Pilhas

Cabeça termostática

Adaptador

Válvula

Com o Bridge conectado ao seu roteador, é criada uma rede de rádio (Zigbee) que permite controlar remotamente a válvula termostática do seu radiador. Você pode conectar quantas válvulas quiser e ativá-las no Garza Smart App ou através do seu assistente de voz (Alexa, Google).

Ele detecta a temperatura ambiente de cada ambiente e, dependendo da temperatura selecionada, o mecanismo abrirá ou fechará o fluxo de água para o radiador, você pode economizar até 25% nos custos de aquecimento.

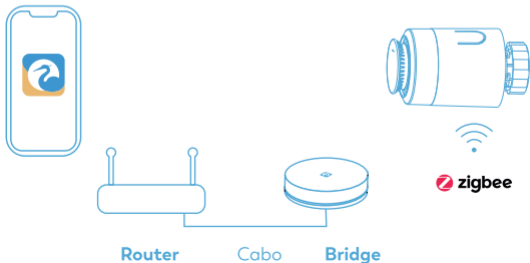

1

Pressione o entalhe para remover o compartimento da bateria e insira as baterias.

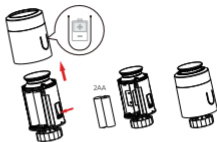

2

Aparafuse a cabeça com a válvula usando o adaptador.



3

Pressione brevemente o botão rotativo. Você verá na tela piscando a palavra "LA". O dispositivo permanecerá configurado com as opções padrão.

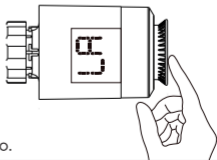



DANFOSS RAV

Válvula 3/4 + êmbolo longo.

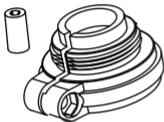

A válvula Danfoss 3/4 precisa instalar um êmbolo longo na parte inferior do controlador. Os acessórios devem ser colocados diretamente na válvula.

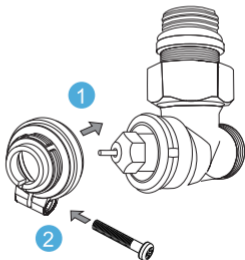
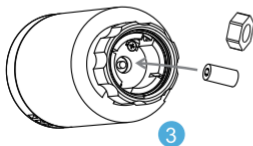

The Danfoss logo, featuring the brand name in a stylized, cursive script.

DANFOSS RA

1/2 Válvula.

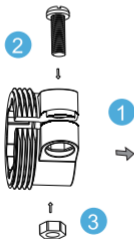
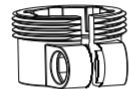

Aperte os parafusos após fixar o conector da válvula.

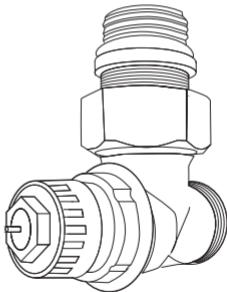

CALEFFI

1/2 Válvula.

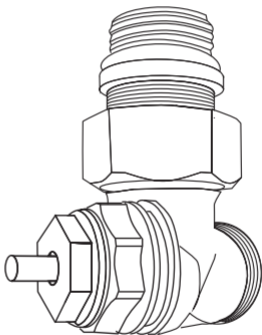
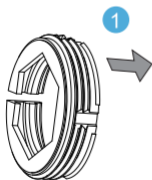

GIACOMINI

1/2 Válvula +
êmbolo curto.

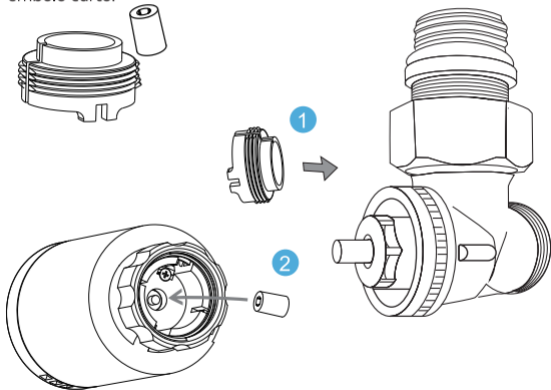

ORKLI

1/2 Válvula de metal + êmbolo de metal fino.

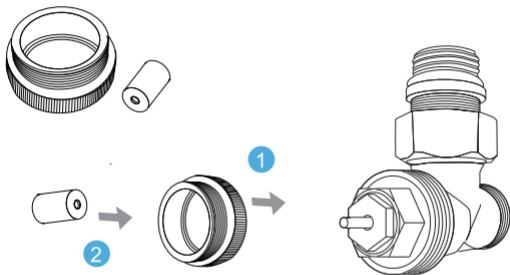

Se tiver uma válvula manual, deverá adquirir uma válvula termostática com um acoplamento do tipo M30 x 1,5 mm. Se você já possui uma válvula termostática, verifique sua compatibilidade neste QR.

INSTALANDO O BRIDGE GARZA (INCLUÍDO NO KIT INICIAL)

65

A instalação da ponte é necessária para sincronizar a cabeça termostática com o app Garza.

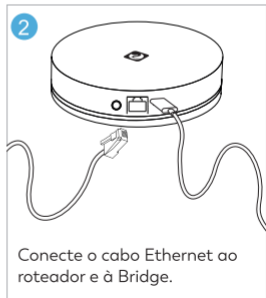
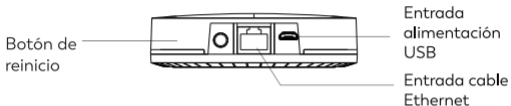

INSTALANDO O BRIDGE GARZA (INCLUÍDO NO KIT INICIAL)

66

Quando a luz vermelha parar de piscar, significa que a ponte está emparelhada corretamente.

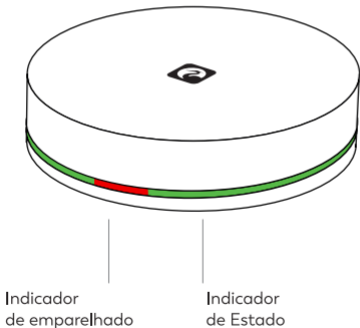

1

Crie uma família (só será necessário criá-la uma vez) para gerenciar todos os dispositivos, para isso acesse o ícone "perfil" localizado no canto inferior direito do app.



2

Selecione "gerenciamento familiar" e "adicionar família". Preencha os dados e salve a família.

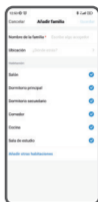

3

Volte para o menu principal do aplicativo e verifique se a família que você acabou de criar está selecionada no canto superior esquerdo. Selecione "adicionar dispositivo".



4

Você verá um menu com dispositivos Garza. Selecione "Bridge".



5

Escolha sua rede Wi-Fi de 2,4 GHz e digite a senha dela.

A senha da sua rede Wi-Fi pode estar na parte de trás do roteador.



6

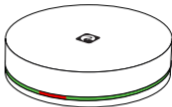

A luz verde no dispositivo Bridge indicará que ele foi emparelhado.

VOCÊ PRECISA DE MAIS INFORMAÇÃO?

Consulte este QR se precisar de informações mais detalhadas sobre como conectar a ponte com seu aplicativo.





BOTÕES DE APLICATIVOS

- 1. Registro.
- 2. Temperatura do quarto.
- 3. Aumentar a temperatura.
- 4. Temperatura desejada.
- 5. Abaixar a temperatura.
- 6. Deslize para ligar e desligar.

- 7. Agendar lembrete de uso.
- 8. Modo de saída: Coloca o termostato em 16°, quando desativado. Ele retornará ao estado anterior.
- 9. Horários.
- 10. Configurações.

1

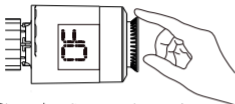

Gire o botão rotativo até que apareça **OF**.

2

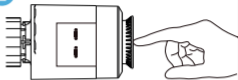

Pressione o botão rotativo em sua cabeça até que o visor mostre **--**.

3



No menu do App Garza, verifique se você está na seção **"Minha casa"**.
Entre na sua ponte.

4



No seu celular, no menu Bridge, Clique em **"Adicionar Dispositivos"** e depois em **"Led Já Pisca" ou "Continuar"**.

5



Aguarde alguns segundos. **"PA"** aparecerá no display principal. Isso indica que a sincronização está correta.

Entre no app e selecione sua válvula.

Selecione **“Programa”**.

Após acessar, você verá o menu de programação, onde deverá selecionar os dias da semana que deseja ter a programação habilitada.

Feito isso, você deve estabelecer os horários a serem configurados dia a dia.

O ícone do sol ☀️ será o primeiro começo do dia, a lua 🌙 o último. 🔄



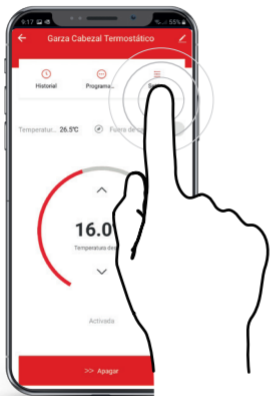

Setting



Proteção de
a válvula



Anticongelante



Detecção de
janela aberta



Proteção infantil



Calibração de
temperatura



Ligar dispositivos

PROTEÇÃO DE VÁLVULA

Se o radiador não estiver funcionando por duas semanas ou mais, ele pode ser danificado ou entupido por ferrugem ou calcário. Portanto, o cabeçote abrirá a válvula e a fará funcionar por 20 segundos a cada duas semanas. O display mostrará **"A5"**.

FUNÇÃO ANTICONGELANTE

Esta função abre a válvula quando a temperatura cai abaixo de 5°C. Quando a temperatura sobe para 8°C, a válvula fecha novamente.

FUNÇÃO JANELA ABERTA

Se a janela estiver aberta e a temperatura cair bruscamente 6°C em um período de 4 minutos, o cabeçote fechará a válvula e mostrará **"OP"** em sua tela. Se a janela estiver fechada e a temperatura ambiente aumentar 2°C, a cabeça voltará a funcionar.

FUNÇÃO DE PROTEÇÃO INFANTIL

Se o botão rotativo for pressionado por alguns segundos, a opção de bloqueio para crianças será ativada, mostrando **"LC"** na tela. Se o botão for pressionado novamente por cerca de 10 segundos, ele será desbloqueado novamente.

CALIBRAÇÃO DE TEMPERATURA

É possível que precisemos ajustar um diferencial de temperatura para compensar a temperatura que a cabeça nos mostra em relação à temperatura “real” (por exemplo, aquela que nos mostra um termômetro que queremos tomar como referência).

ALARME

Durante o seu funcionamento normal.
Se o sensor NTC estiver danificado, “ER” será exibido.

AVISO DE BATERIA FRACA

Quando a bateria do cabeçote estiver fraca, ela exibirá um ícone de bateria fraca.

SOBRESCREVER TEMPORARIAMENTE

Durante uma programação pré-estabelecida, se desejar modificar a temperatura manualmente, pode rodar o botão rotativo. A nova configuração manual permanecerá até o final do período de programação.

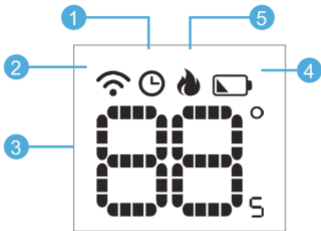

Modo de programação.

Conectado.

Indicador de temperatura.

Bateria Fraca.

Funcionando.

Do aplicativo Alexa | OK Google, você pode procurar o Skill Garza Smart. Depois de instalá-lo, você deve inserir seus dados de login do aplicativo Garza.

Para controlar este dispositivo por voz pode seguir as indicações que encontrará nos QRs.



Configurar com Alexa



Configurar com Google

COMO INTERLIGAR AS VÁLVULAS TERMOSTÁTICAS?

A principal vantagem das cabeças ou válvulas termostáticas é poder controlar a temperatura de cada radiador da sua casa, mas se quiser combinar várias cabeças que controlem uma área maior, pode fazê-lo. Para isso, siga os passos indicados em este QR.



O VISOR DA MINHA VÁLVULA TERMOSTÁTICA ESTÁ INVERTIDO

As letras da sua válvula termostática estão invertidas e você não consegue vê-las corretamente? Saiba como o resolver, para o fazer siga os passos que lhe indicamos neste QR.



DECLARACION DE CONFORMIDAD UE
EU DECLARATION OF CONFORMITY / DECLARAÇÃO DE
CONFORMIDADE UE

1. Gama de producto & Modelo./ Product range & model.
/ Gama de produto & Modelo

Referencia/ Reference/ Referência: 401307G, 401317G

Descripción/ Description/ Descrição: GZ TRV SMTZB
CABEZAL TERMOSTAT

EAN: 8430624013070, 8430624013179

2. Nombre y dirección del importador./ Importer name and
adress.

/ Nome e morada do importador.

Imprex Europe, S.L.

Avenida de la Industria, 22, Polígono Industrial la Cantueña,
CP 28947 Fuenlabrada, Madrid,

CIF N° B-2811576

3. Esta declaración de conformidad se expide bajo la
exclusiva responsabilidad del fabricante./ This declaration of
conformity is issued under the sole responsibility of the
manufacturer./ Esta declaração de conformidade redige-se
sobre a exclusiva responsabilidade do criador

4. Objeto de la declaración./ Object of the declaration./
Objeto da declaração.

N/A

5&6 El objeto de la declaración descrito anteriormente cumple con las siguientes normas y directivas:/ The object of the declaration described above is in conformity with the following normatives and directives:/ O objeto da declaração, descrito anteriormente, cumpre com as seguintes normas e diretivas:

2014/53/EU	EN 6100-3-3:2013 + A1:2019
2015/863/EU amending annex II to 2011/65/EU	EN 55035:2017+A11:2020
2014/35/EU	EN 300 440 V2.2.1
EN 60730-1:2016+A1:2019	EN 61000-3-2:2019+A1:2021
EN 60730-2-9:2019+A1:2019+A2:2020	
EN 55032:2015+A1:2020+A11:2020	
EN 301 489-1 V2.2.3	

7. Información adicional./ Aditonal information./ Informaçãõ adicional.

N/A

8. A los efectos oportunos se firma el presente documento./ Signed by./ Pelos efeitos oportunos se assina o presente documento.

IMPRES EUSOPE S.L.
C.I.F. 28011800
Calle de la Industria 20
28011 Madrid, España
Tel: +34 91 481 11 11
Fax: +34 91 481 11 12
www.impres.com

Luis González
CFO

08/07/2022

Garantía / Warranty / Garantia

Este producto tiene una garantía de 3 años.

Cualquier daño o desperfecto causado por una persona, o un uso indebido del dispositivo, anularán inmediatamente la garantía del producto.

This product has a 3-year warranty.

Any damage or damage caused by a person, or improper use of the device, will immediately void the product warranty.

Este produto tem garantia de 3 anos.

Qualquer dano ou dano causado por uma pessoa, ou uso indevido do dispositivo, anulará imediatamente a garantia do produto.

Protección Medioambiental / Environmental Protection / Proteção Ambiental

Los productos eléctricos no deben tirarse junto con los desechos domésticos, deben llevarse a un punto ecológico comunitario de recogida de este tipo de materiales, de acuerdo con la legislación local.

Póngase en contacto con las autoridades locales o con su vendedor, para que le aconsejen sobre el reciclaje. El material de embalaje es reciclable. Deshágase del embalaje de manera ecológica y de forma que el servicio de recogida pueda acceder fácilmente al material reciclable.

Electrical products must not be disposed of with household waste, they must be taken to a community ecological collection point for this type of material, in accordance with local legislation.

Contact your local authorities or your dealer for advice on recycling. The packaging material is recyclable. Dispose of the packaging in an ecological way and in a way that the collection service can easily access the recyclable material.

Os produtos elétricos não devem ser descartados com o lixo doméstico, devem ser levados a um ponto de coleta ecológica da comunidade para este tipo de material, de acordo com a legislação local.

Contacte as autoridades locais ou o seu revendedor para obter informações sobre reciclagem. O material da embalagem é reciclável. Descarte a embalagem de forma ecológica e de forma que o serviço de coleta tenha fácil acesso ao material reciclável.

Información de seguridad / Safety information Informação de Segurança

Las baterías pueden explotar o tener fugas y causar quemaduras y lesiones si se recargan, son arrojadas al fuego, son utilizadas con baterías de otro tipo, si son desmontadas o si están mal insertadas.

Reemplazar siempre todas las baterías al mismo tiempo.

No transportar ni llevar las baterías sueltas en los bolsillos o bolsos.

No extraer la etiqueta de la batería.

Mantener las baterías fuera del alcance de los niños. En caso de ingestión acuda inmediatamente al médico.

Las pilas deben retirarse del dispositivo antes de desguazar y las pilas deben desecharse de manera segura.

Batteries may explode or leak, and cause burn injury if recharged, disposed of in fire, mixed with a different battery type, inserted backwards or disassembled.

Replace all used batteries at the same time.

Do not carry batteries loose in your pocket or purse.

Do not remove the battery label.

Keep batteries away from children. If swallowed, consult a physician at once.

The battery must be removed from the device before it is scrapped and the battery is to be disposed of safely.

As baterias podem explodir ou vazar e causar queimaduras ou ferir se forem recarregadas, lançadas ao lume, usadas com outros tipos de baterias, desmontadas ou ser inseridas incorretamente.

Substitua sempre todas as pilhas ao mesmo tempo.

Não transportar ou levar baterias soltas em bolsos ou bolsas.

Não remove a etiqueta da bateria.

Mantenha as baterias fora do alcance das crianças. Em caso de ingestão consulte um médico imediatamente.

As baterias devem ser removidas do dispositivo antes do descarte e as baterias devem ser descartadas com segurança.

Imprex Europe S.L. Avda. de la Industria 22-26
28947 Fuenlabrada, Madrid NIF B28115764
Made in PRC | imprexeurope.com | garza.es



RoHS



