

# CH-8 R

*Estufa de Leña de Rincón con Horno en Acero Inoxidable*



## CARACTERÍSTICAS TÉCNICAS

**Potencia Térmica Máxima** 11,7 kW.

**Potencia Nominal** 9,5 kW.

**Temperatura de Humos Media** 173 °C.

**Rendimiento** 81 %.

**Combustible** Leña.

**Volumen Calefactable** 260 m<sup>3</sup>.

**Consumo** 2,76 kg/h.

**CO al 13% O<sub>2</sub>** 0,08 %.

**Partículas al 13% O<sub>2</sub>** 35,00 mg/Nm<sup>3</sup>.

**Equipo elaborado en Acero** Hasta 4 mm.

**Regulación Entrada de Aire** Primario y Secundario

**Pintura Anticalórica** 800°C. Color Negro.

**Tamaño de Tronco** 65 cm.

**Peso** 128 kg.

**Medidas (Ancho x Fondo x Alto)** 1000 x 630 x 1121 mm.

**Medidas Frontal (Alto x Ancho)** -

**Medidas Horno (AxFxH)** 491 x 362 x 236 mm.

## EQUIPAMIENTO

- Sistema de Doble Combustión y Cristal Limpio.
- Medidas Entrada Leña (AxHxF): 491 x 280 x 580 mm.
- Salida Humos Macho Ø 150 mm en fundición.
- Cristal Vitrocerámico 750 °C.
- Interior Cámara en Vermiculita.
- Puerta y Rejilla de fundición.
- Interior del Horno en Acero Inoxidable.
- Base del Horno en Ladrillo Refractario.
- Termómetro de Vaina.
- Bandeja y Parrilla Inox. 450 x 350 mm.
- Termómetro de Vaina.
- Parrilla de Asados Giratoria 310 x 300 mm.

## ACCESORIOS

- Bote de Spray Pintura Anticalórica 800°C. Color Negro.
- Manguito Anticondensaciones. Negro Vitrificado.
- Placa de Acero Protector 900 x 705 mm. Color Negro.

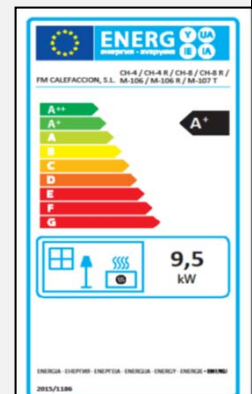

# CH-8 R

## Ficha Técnica

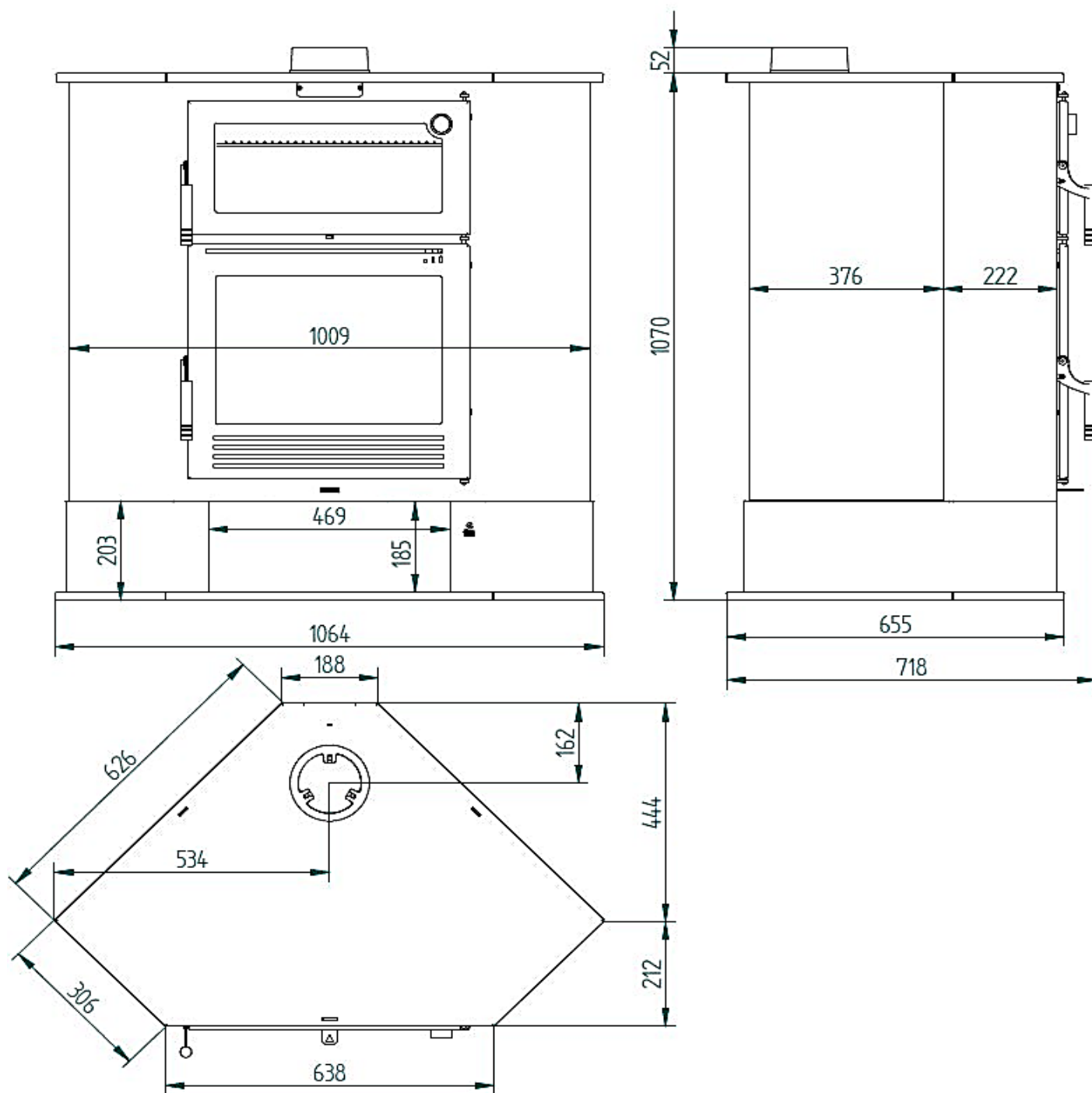

# CH-8 R

Corner Wood Stove with Stainless Steel Oven



## EQUIPMENT

- Double Combustion and Clean Glass System.
- Firewood Measures (WxDxH): 491 x 280 x 580 mm.
- Output Male Fumes Ø 150 mm in cast iron.
- Glass-ceramic glass 750 °C.
- Interior Camera in Vermiculite.
- Cast iron door and grid.
- Interior of the Oven in Stainless Steel.
- Base of the Furnace in Refractory Brick.
- Sheath thermometer.
- Tray and Stainless Steel Grill. 450 x 350 mm.
- Sheath thermometer.
- Rotating Roast Grill 310 x 300 mm.

## SPECIFICATIONS

**Maximum Thermal Input** 11,7 kW.

**Rated Power** 9,5 kW.

**Medium Smoke Temperature** 173 °C.

**Yield** 81 %.

**Fuel** Wood.

**Heated Volume** 260 m<sup>3</sup>.

**Consumption** 2,76 kg/h.

**CO 13% O<sub>2</sub>** 0,08 %.

**Particulate matter at 13% O<sub>2</sub>** 35,00 mg/Nm<sup>3</sup>.

**Equipment made of Steel** Up to 4 mm.

**Primary and Secondary Air Intake Regulation**

**Anticaloric Paint** 800°C. Black color.

**Trunk Size** 65 cm.

**Weight** 128 kg.

**Measurements (WxDxH)** 1000 x 630 x 1121 mm.

**Front Measurements (HxW) -**

**Oven measures (WxDxH)** 491 x 362 x 236 mm.

## ACCESSORIES

- Spray Bottle Anticaloric Paint 800°C. Black Color.
- Anti-condensation cuff. Black Vitrified.
- Protective Steel Plate 900 x 705 mm. Black Color.

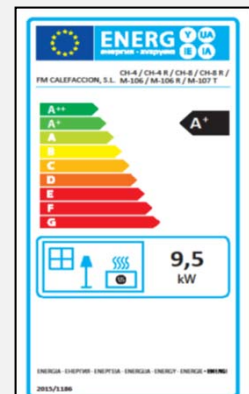

# CH-8 R

## Data Sheet

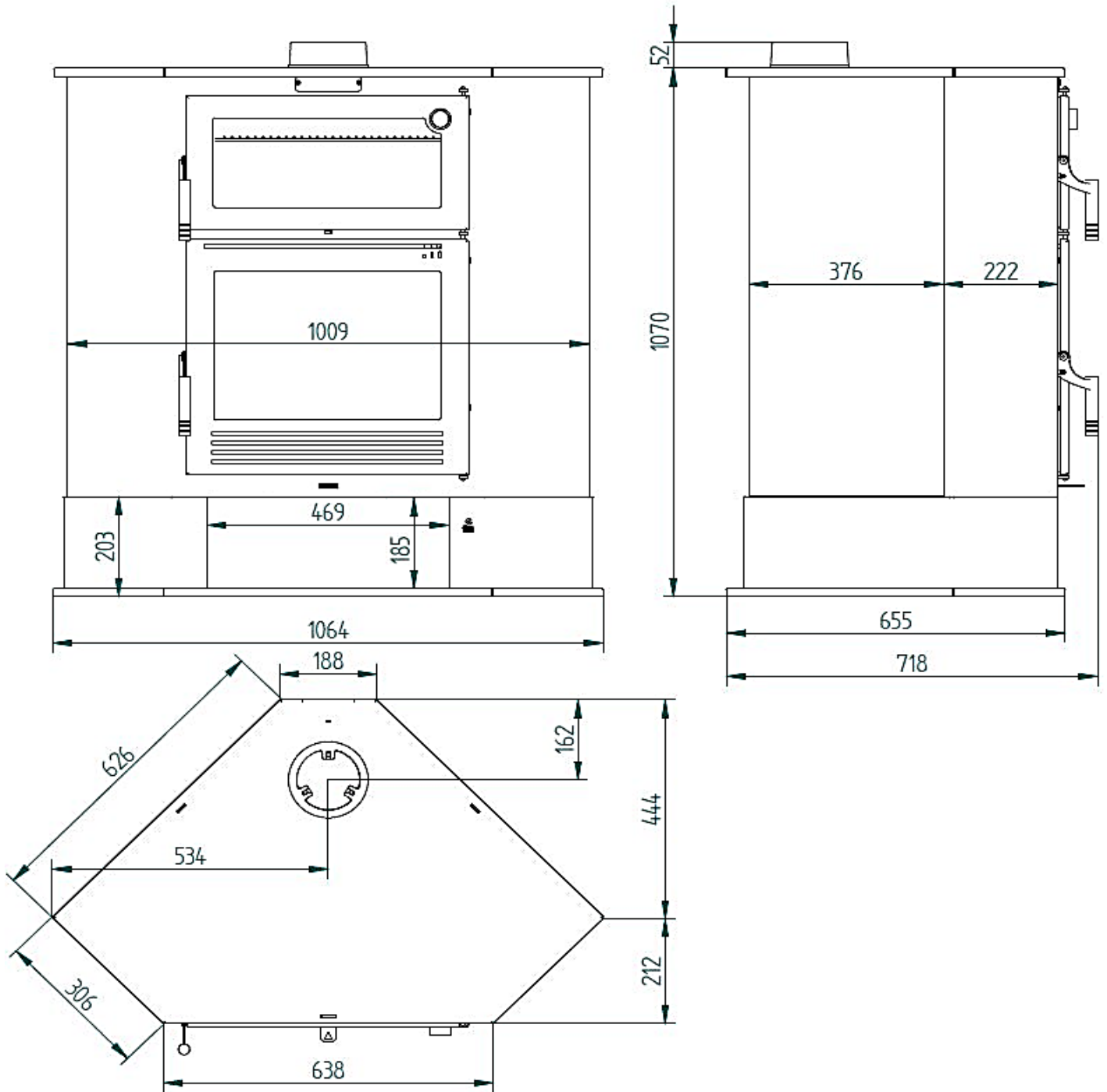

# CH-8 R

Coin Poêle à bois avec Four en Acier Inoxydable



## SPECIFICATIONS

**Puissance Thermique Maximale** 11,7 kW.

**Puissance Nominale** 9,5 kW.

**Température Moyenne de Fumée** 173 °C.

**Rendement** 81 %.

**Combustible** Bois à brûler.

**Volume Chauffé** 260 m<sup>3</sup>.

**Consommation** 2,76 kg/h.

**CO 13% O2** 0,08 %.

**Matières particulaires 13 % O2** 35,00 mg/Nm<sup>3</sup>.

**Équipement en Acier** Jusqu'à 4 mm.

**Règlement sur les prises d'air primaire et secondaire**

**Peinture Anticalorique** 800°C. Couleur noire.

**Taille du tronc** 65 cm.

**Poids** 128 kg.

**Mesures (L x P x H)** 1000 x 630 x 1121 mm.

**Mesures avant (H x L)** -

**Mesures du four (AxFxH)** 491 x 362 x 236 mm.

## ÉQUIPEMENT

- Double combustion et système de verre propre.
- Mesures d'intrants bois (AxHxF): 491 x 280 x 580 mm.
- Sortie de fumées mâle Ø 150 mm en fonte.
- Verre vitrocéramique 750 °C.
- Caméra intérieure en vermiculite.
- Porte et grille en fonte.
- Intérieur du four en acier inoxydable.
- Base du four en brique réfractaire.
- Thermomètre gaine.
- Plateau et grille en acier inoxydable. 450 x 350 mm.
- Thermomètre gaine.
- Grille rotative 310 x 300 mm.

## ACCESSOIRES

- Peinture chaude en aérosol 800°C. Couleur Noir.
- Brassard anti-condensation. Noir vitrifié.
- Plaque d'acier de protection 900 x 705 mm. Couleur Noir.

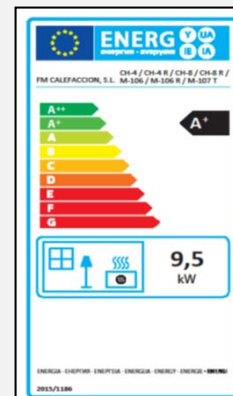

# CH-8 R

## Fiche Technique

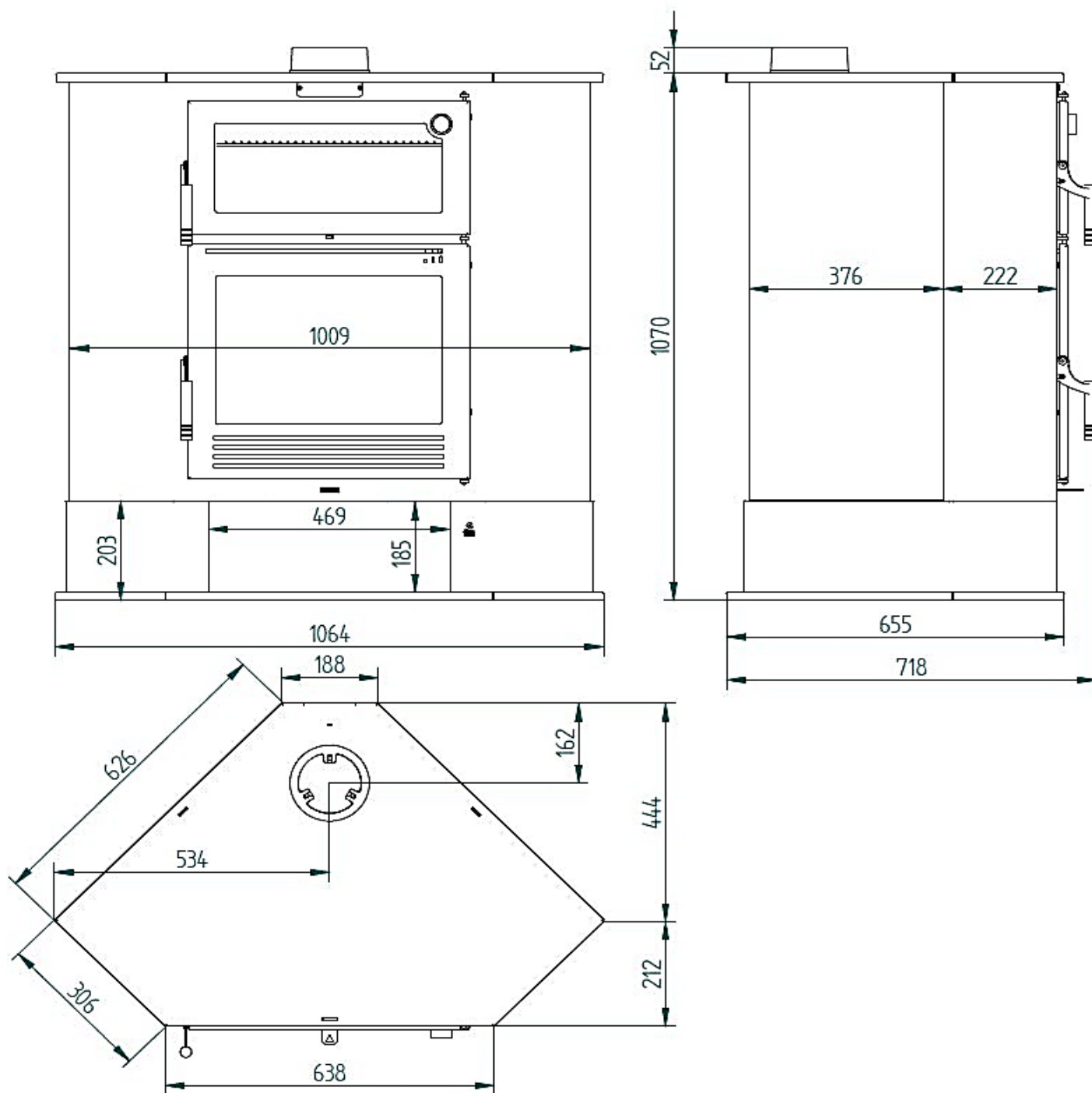

# CH-8 R

*Eck-Holzofen mit Backofen aus Edelstahl*



## AUSRÜSTUNG

- Doppeltes Verbrennungssystem und sauberes Glas.
- Maße des Holzeingangs (BxHxT): 491 x 280 x 580 mm.
- Männlicher Rauchabzug Ø 150 mm aus Gusseisen.
- Glaskeramikglas 750 °C.
- Innenkammer aus Vermiculit.
- Tür und Gitter aus Gusseisen.
- Innenraum des Edelstahlofens.
- Boden eines feuerfesten Steinofens.
- Mantel-Thermometer.
- Tablett und Grill aus Edelstahl. 450 x 350 mm.
- Mantel-Thermometer.
- Rotierender Bratgrill 310 x 300 mm.

## LEISTUNGSBESCHREIBUNG

**Maximale thermische Leistung** 11,7 kW.  
**Belastbarkeit** 9,5 kW.  
**Mittlere Rauchtemperatur** 173 °C.  
**Ertrag** 81 %.  
**Brennstoff** Holz.  
**Beheiztes Volumen** 260 m<sup>3</sup>.  
**Verbrauch** 2,76 kg/h.  
**CO al 13% O2** 0,08 %.  
**Feinstaub mit 13 % O2** 35,00 mg/Nm<sup>3</sup>.  
**Ausrüstung aus Stahl** Bis zu 4 mm.  
**Regelung des Primär- und Sekundärlufteinlasses**  
**Hitzebeständige Farbe** 800°C. Schwarze Farbe.  
**Logarithmus-Größe** 65 cm.  
**Gewicht** 128 kg.  
**Maße (Breite x Tiefe x Höhe)** 1000 x 630 x 1121 mm.  
**Vordere Maße (Höhe x Breite) -**  
**Maße des Ofens (BxTxH)** 491 x 362 x 236 mm.

## ZUBEHOR

- Hitzebeständige Farbsprühdose 800°C. Schwarze Farbe.
- Anti-Kondensations-Hülse. Feinsteinzeug schwarz.
- Schützende Stahlplatte 900 x 705 mm. Schwarze Farbe.

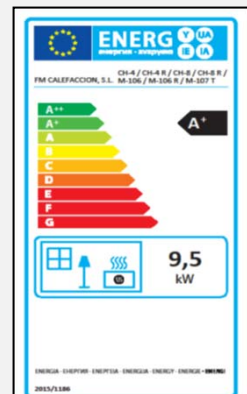

# CH-8 R

Laken

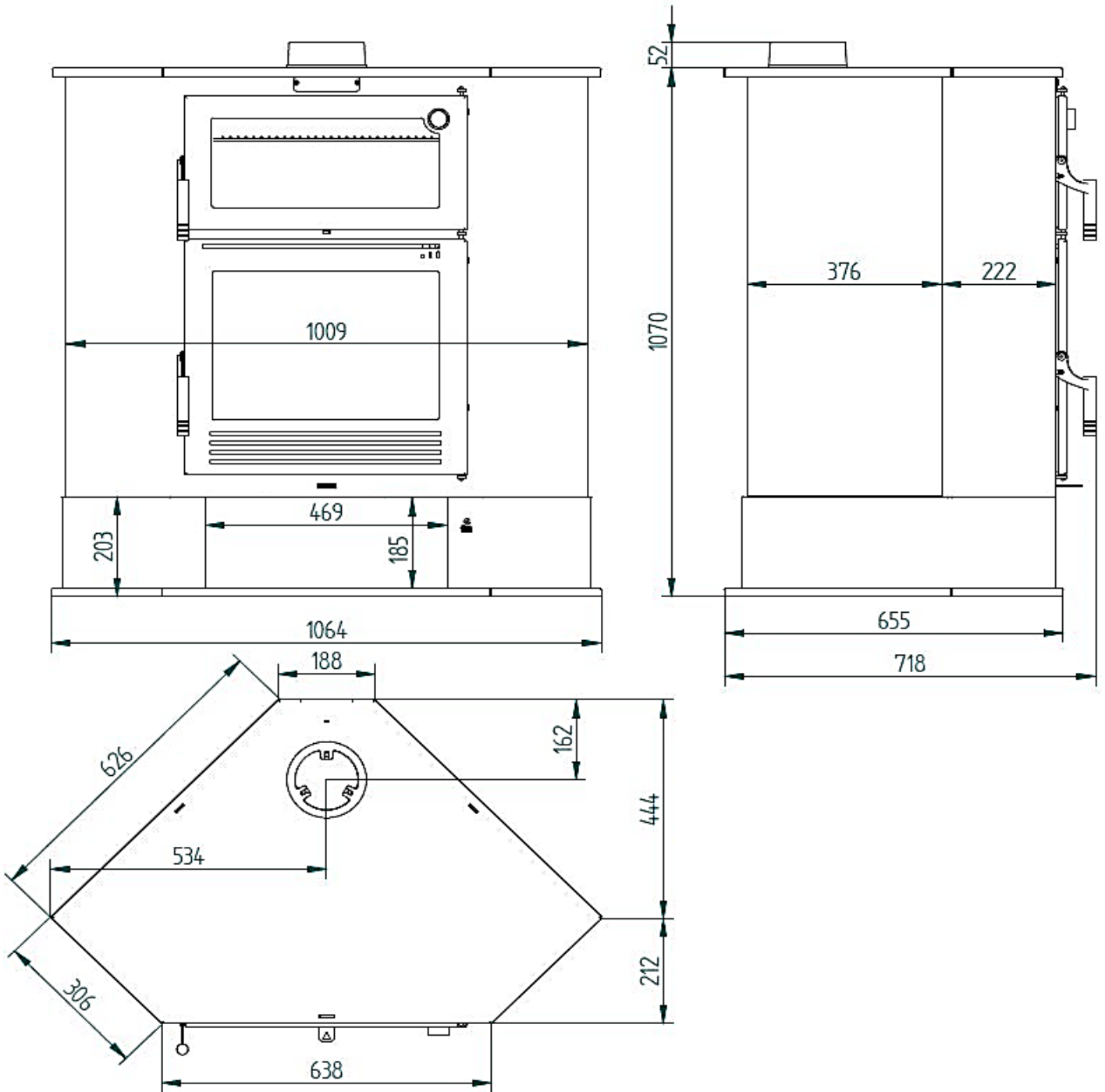



# CH-8 R

Fogão a Lenha de Canto com Forno em Aço Inoxidável



## ESPECIFICAÇÕES

**Potência Térmica Máxima** 11,7 kW.

**Potência Nominal** 9,5 kW.

**Temperatura Média de Fumo** 173 °C.

**Rendimento** 81 %.

**Combustível** Lenha.

**Volume Aquecido** 260 m<sup>3</sup>.

**Consumo** 2,76 kg/h.

**CO 13% O<sub>2</sub>** 0,08 %.

**Partículas em Suspensão 13% O<sub>2</sub>** 35,00 mg/Nm<sup>3</sup>.

**Equipamento em Aço** Até 4 mm.

**Regulação da Admissão Ar Primária e Secundária**

**Tinta Anticalórica** 800°C. Cor preta.

**Tamanho do Tronco** 65 cm.

**Peso** 128 kg.

**Medições (LxPxA)** 1000 x 630 x 1121 mm.

**Medições Frontais (AxL)** -

**Medidas do forno (LxPxA)** 491 x 362 x 236 mm.

## EQUIPAMENTOS

- Combustão dupla e sistema de vidro limpo.
- Medidas entrada lenha (LxPxA): 491 x 280 x 580 mm.
- Saída fumos machos Ø 150 mm em ferro fundido.
- Vidro vitrocerâmico a 750 °C.
- Câmara interior em vermiculita.
- Porta e grade de fundição.
- Interior do forno em aço inoxidável.
- Base do Forno em Tijolo Refratário.
- Termômetro da bainha.
- Bandeja e grelha em aço inoxidável. 450 x 350 mm.
- Termômetro da bainha.
- Grelha Assada Rotativa 310 x 300 mm.

## ACESSÓRIOS

- Frasco de Spray Tinta Anticalórica 800°C. Cor Preto.
- Punho anti-condensação. Preto Vitrificado.
- Placa de aço protetora 900 x 705 mm. Cor Preto.

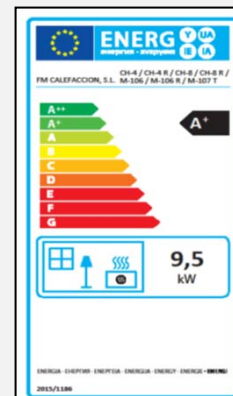

# CH-8 R

## Ficha Técnica

