

HLI-100

Horno de Leña para encastrar con Bandeja de 50 cm.



EQUIPAMIENTO

- Sistema de Doble Combustión y Cristal Limpio.
- Medidas Entrada Leña (AxHxF): 500 x 335 x 400 mm.
- Salida Humos Macho Ø 200 mm en fundición.
- Cristal Vitrocerámico 750 °C.
- Puerta y Rejilla de fundición.
- Interior del Horno en Acero Inoxidable.
- Base del Horno en Ladrillo Refractario.
- Termómetro de Vaina.
- Bandeja y Parrilla Inox. 500 x 350 mm.
- Doble Cámara.
- Parrilla de Asados Giratoria 310 x 300 mm.

CARACTERÍSTICAS TÉCNICAS

Potencia Térmica Máxima 11,7 kW.

Potencia Nominal 9,5 kW.

Temperatura de Humos Media 173 °C.

Rendimiento 81 %.

Combustible Leña.

Volumen Calefactable 260 m³.

Consumo 2,76 kg/h.

CO al 13% O₂ 0,08 %.

Partículas al 13% O₂ 35,00 mg/Nm³.

Equipo elaborado en Acero Hasta 4 mm.

Regulación Entrada de Aire Primario y Secundario

Pintura Anticalórica 800°C. Color Negro.

Tamaño de Tronco 65 cm.

Peso 115 kg.

Medidas (Ancho x Fondo x Alto) 615 x 392 x 1050 mm.

Medidas Frontal (Alto x Ancho) 1105 x 792 mm.

Medidas Horno (AxFxH) 505 x 360 x 300 mm.

ACCESORIOS

- Bote de Spray Pintura Anticalórica 800°C. Color Negro.
- Manguito Anticondensaciones. Negro Vitrificado.

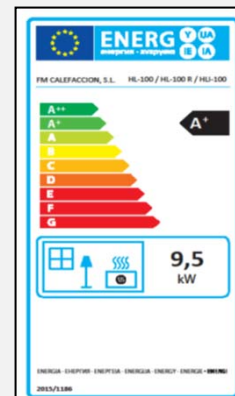

HLI-100

Versiones



HLI-100. Interior Vermiculita.

HLI-100 F. Interior Fundición.

Ficha Técnica

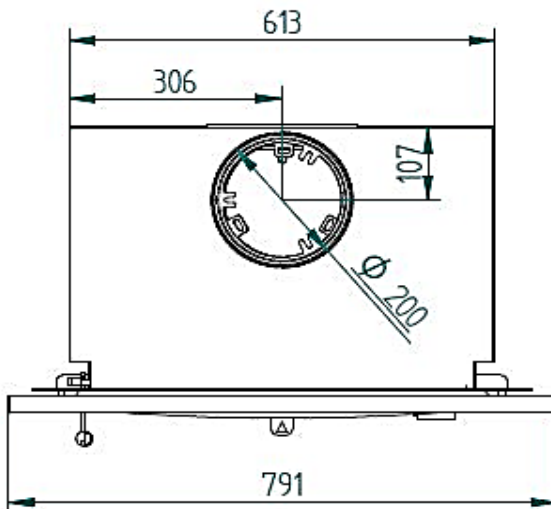
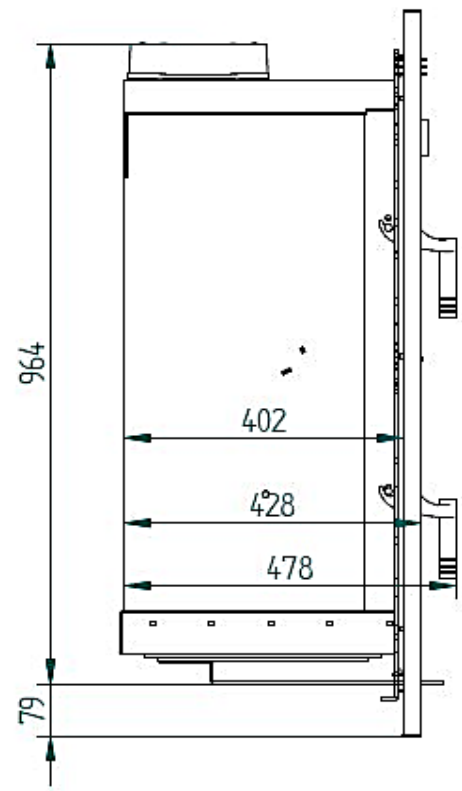
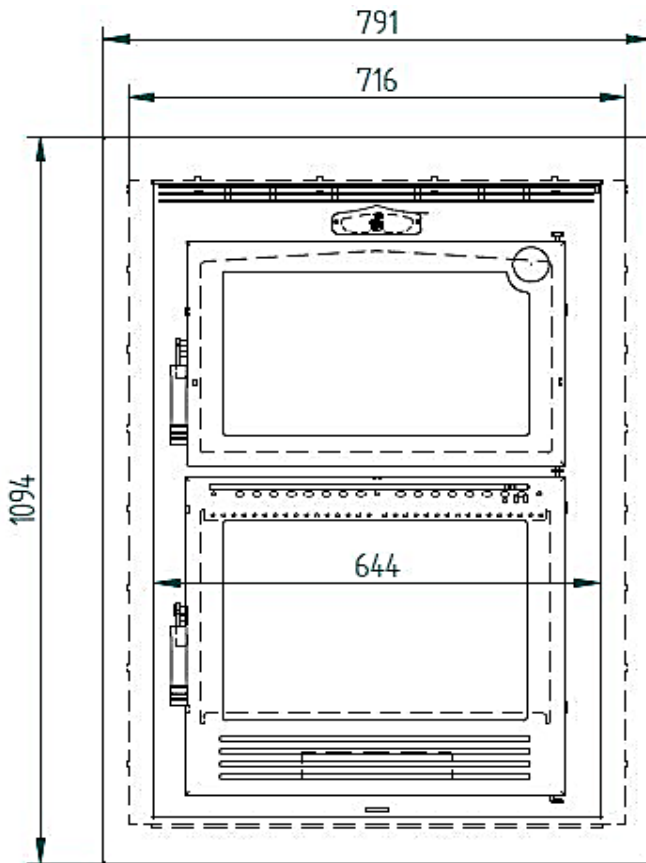

HLI-100

Wood Oven to fit with Tray of 50 cm.



EQUIPMENT

- Double Combustion and Clean Glass System.
- Firewood Measures (WxDxH): 500 x 335 x 400 mm.
- Output Male Fumes Ø 200 mm in cast iron.
- Glass-ceramic glass 750 °C.
- Cast iron door and grid.
- Interior of the Oven in Stainless Steel.
- Base of the Furnace in Refractory Brick.
- Sheath thermometer.
- Tray and Stainless Steel Grill. 500 x 350 mm.
- Dual Camera.
- Rotating Roast Grill 310 x 300 mm.

SPECIFICATIONS

Maximum thermal input 11,7 kW.

Rated Power 9,5 kW.

Medium Smoke Temperature 173 °C.

Yield 81 %.

Fuel Wood.

Heated Volume 260 m3.

Consumption 2,76 kg/h.

CO al 13% O2 0,08 %.

Particulate matter at 13% O2 35,00 mg/Nm3.

Equipment made of Steel Until 4 mm.

Primary and Secondary Air Intake Regulation

Anticaloric Paint 800°C. Black Color.

Trunk Size 65 cm.

Weight 115 kg.

Measurements (WxDxH) 615 x 392 x 1050 mm.

Front Measurements (HxW) 1105 x 792 mm.

Oven measures (WxDxH) 505 x 360 x 300 mm.

ACCESSORIES

- Spray Bottle Anticaloric Paint 800°C. Black Color.
- Anti-condensation cuff. Black Vitrified.

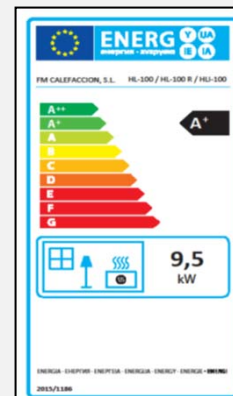

HLI-100

Versions



HLI-100. Vermiculite Interior.

HLI-100 F. Cast Iron Interior.

Data Sheet

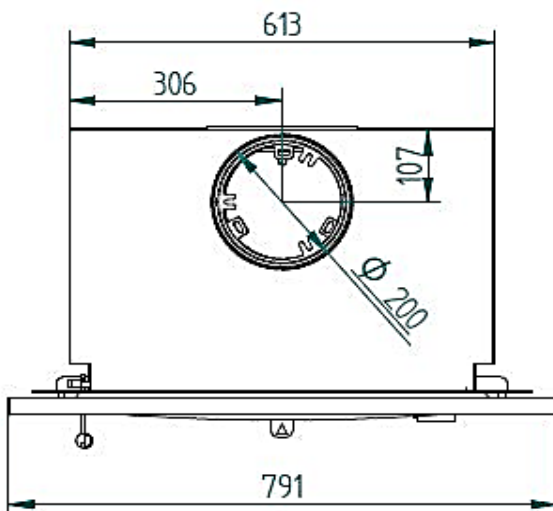
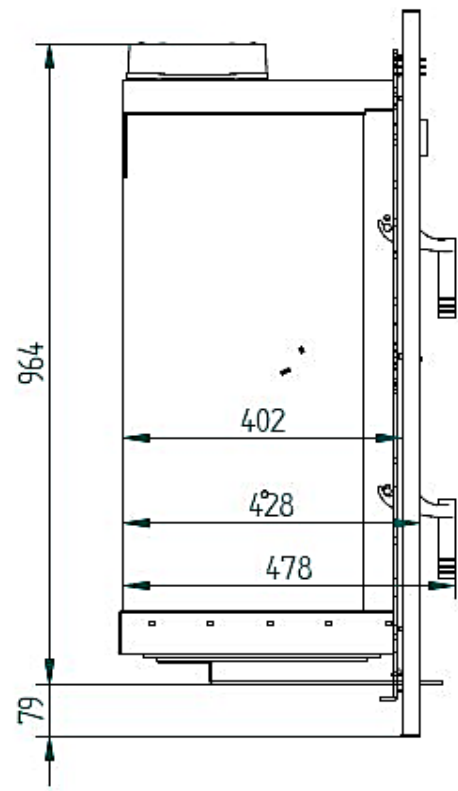
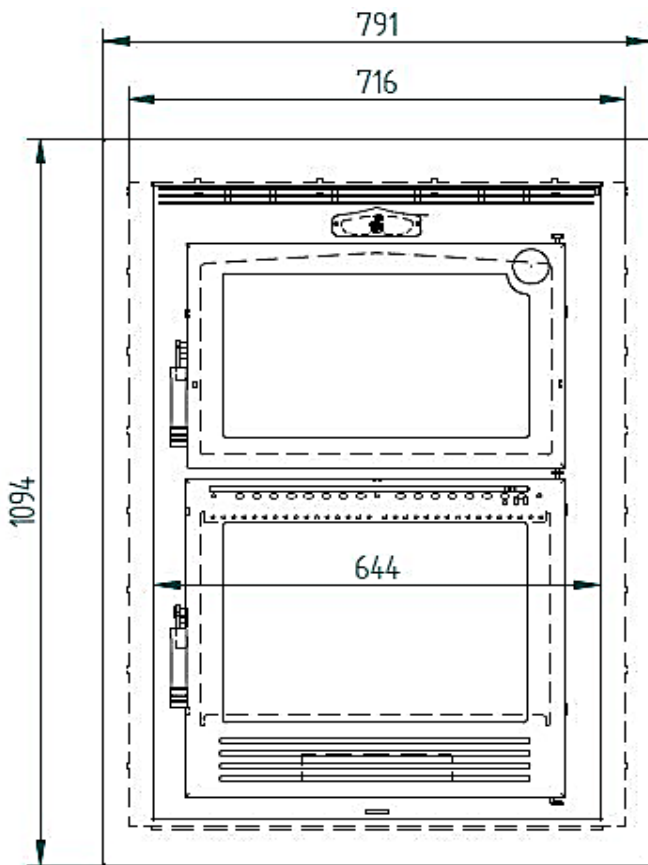

HLI-100

Four à Bois à Installer avec Plateau de 50 cm.



ÉQUIPEMENT

- Double combustion et système de verre propre.
- Mesures d'intrants bois (AxHxF): 500 x 335 x 400 mm.
- Sortie de fumées mâle Ø 200 mm en fonte.
- Verre vitrocéramique 750 °C.
- Porte et grille en fonte.
- Intérieur du four en acier inoxydable.
- Base du four en brique réfractaire.
- Thermomètre gainé.
- Plateau et grille en acier inoxydable. 500 x 350 mm.
- Double caméra.
- Grille rotative 310 x 300 mm.

SPECIFICATIONS

Puissance thermique maximale 11,7 kW.
Puissance nominale 9,5 kW.
Température moyenne de fumée 173 °C.
Rendement 81 %.
Combustible Bois à brûler.
Volume chauffé 260 m³.
Consommation 2,76 kg/h.
CO al 13% O2 0,08 %.
Matières particulaires 13 % O2 35,00 mg/Nm³.
Équipement en acier Jusqu'à 4 mm.
Règlement sur les prises d'air primaire et secondaire
Peinture anticorrosive 800°C. Couleur Noir.
Taille du tronc 65 cm.
Poids 115 kg.
Mesures (L x P x H) 615 x 392 x 1050 mm.
Mesures avant (H x L) 1105 x 792 mm.
Mesures du four (AxFxH) 505 x 360 x 300 mm.

ACCESSOIRES

- Peinture chaude en aérosol 800°C. Couleur Noir.
- Brassard anti-condensation. Noir vitrifié.

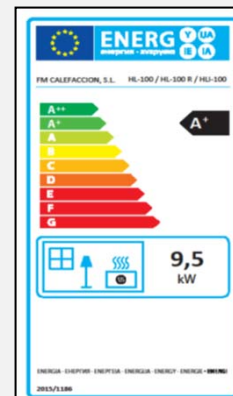

HLI-100

Versions



HLI-100. Vermiculite intérieure.

HLI-100 F. Fonderie intérieure.

Fiche technique

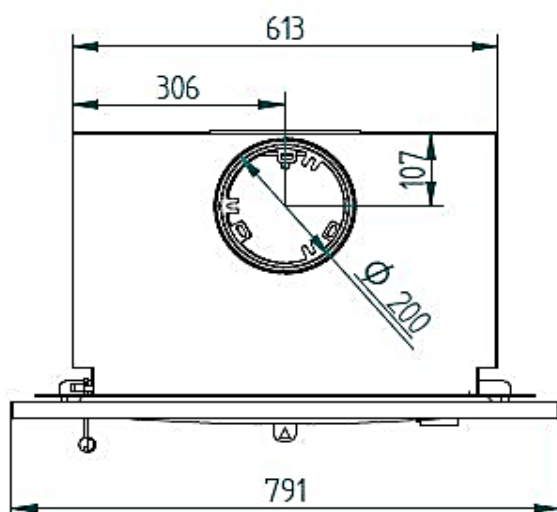
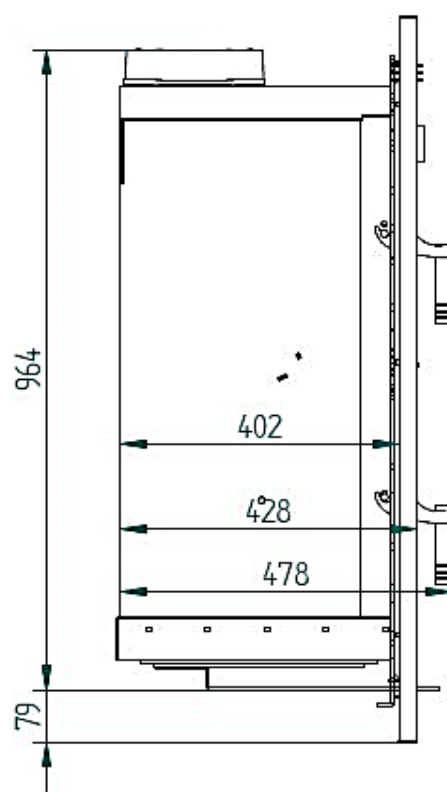
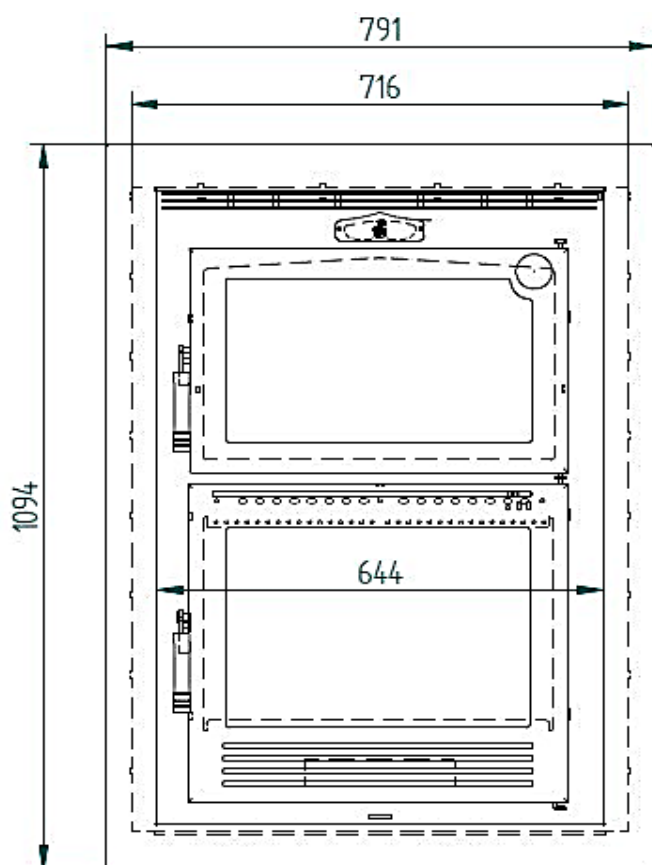

HLI-100

Forno de Lenha Embutido com Bandeja de 50 cm.



EQUIPAMENTOS

- Combustão dupla e sistema de vidro limpo.
- Medidas entrada lenha (LxPxA): 500 x 335 x 400 mm.
- Saída fumos machos Ø 200 mm em fundição.
- Vidro vitrocerâmico a 750 °C.
- Porta e grade de fundição.
- Interior do forno em aço inoxidável.
- Base do Forno em Tijolo Refratário.
- Termômetro da bacia.
- Bandeja e grelha em aço inoxidável. 500 x 350 mm.
- Câmara dupla.
- Grelha Assada Rotativa 310 x 300 mm.

ESPECIFICAÇÕES

Potência Térmica Máxima 11,7 kW.

Potência Nominal 9,5 kW.

Temperatura Média de Fumo 173 °C.

Rendimento 81 %.

Combustível Lenha.

Volume Aquecido 260 m³.

Consumo 2,76 kg/h.

CO 13% O₂ 0,08 %.

Partículas em Suspensão 13% O₂ 35,00 mg/Nm³.

Equipamento em Aço Até 4 mm.

Regulação da Admissão Ar Primária e Secundária

Tinta Anticalórica 800°C. Cor Preto.

Tamanho do Tronco 65 cm.

Peso 115 kg.

Medições (LxPxA) 615 x 392 x 1050 mm.

Medições Frontais (AxL) 1105 x 792 mm.

Medidas do forno (LxPxA) 505 x 360 x 300 mm.

ACESSÓRIOS

- Frasco de Spray Tinta Anticalórica 800°C. Cor Preto.
- Punho anti-condensação. Preto Vitrocerâmico.

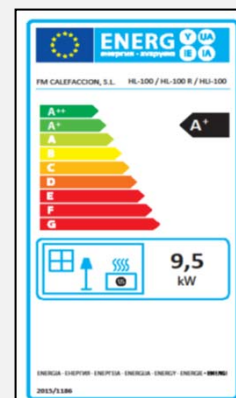

HLI-100

Versões



HLI-100. Interior Vermiculita.

HLI-100 F. Interior Fundição.

Folha

